



**Al-Mamoon University**  
**College of Science**  
**Department of Medical Physics**

**EX (1):**

**AND GATE**

**By:**

**Humam A. Arrak**

## The purpose of the experiment

Learn about the function of the AND gate.

## Gate symbol

It is as shown in the figure below:



Figure 1

## Number of possibilities

The number of input possibilities for the gate is determined using the following relationship:

$$\text{number of possibilities} = 2^n$$

where (n) is the number of entries.

## Logical equation:

$$Y = A \cdot B$$

## Physical Principle

The logical symbol for an (AND) gate with two inputs as in Figure (1), where both A and B are two inputs to the gate, and Y is an output of the gate. The electrical circuit of the (AND) gate can be represented in figure (2), we note that the lamp is in the (ON) state only when both switches are closed.

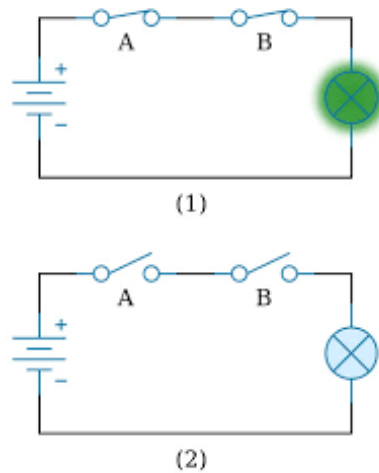

Figure 2

A two-entry (**AND**) gate can be described by the following truth table :

Input		Output
A	B	$Y = A.B$
0	0	0
0	1	0
1	0	0
1	1	1

### Devices used

- Diodes
- DC Power supply (5V)
- Resistance (1K $\Omega$ )
- LED Diode

