

Fundamentals of
Electric Circuits
First Course

Dr. Omar K. Alazzawi

Chapter ONE

Basic Concepts

SYSTEMS OF UNITS

TABLE I.2 The SI prefixes.

Multiplier	Prefix	Symbol
10^{18}	exa	E
10^{15}	peta	P
10^{12}	tera	T
10^9	giga	G
10^6	mega	M
10^3	kilo	k
10^2	hecto	h
10	deka	da
10^{-1}	deci	d
10^{-2}	centi	c
10^{-3}	milli	m
10^{-6}	micro	μ
10^{-9}	nano	n
10^{-12}	pico	p
10^{-15}	femto	f
10^{-18}	atto	a

TABLE I.1 The six basic SI units.

Quantity	Basic unit	Symbol
Length	meter	m
Mass	kilogram	kg
Time	second	s
Electric current	ampere	A
Thermodynamic temperature	kelvin	K
Luminous intensity	candela	cd

CHARGE AND CURRENT

Charge is an electrical property of the atomic particles of which matter consists, measured in coulombs (C)

The following points should be noted about electric charge:

1. The coulomb is a large unit for charges. In 1 C of charge, there are $1/(1.602 \times 10^{-19}) = 6.24 \times 10^{18}$ electrons. Thus realistic or laboratory values of charges are on the order of pC, nC, or μC .
2. According to experimental observations, the only charges that occur in nature are integral multiples of the electronic charge $e = -1.602 \times 10^{-19} \text{ C}$.
3. The *law of conservation of charge* states that charge can neither be created nor destroyed, only transferred. Thus the algebraic sum of the electric charges in a system does not change.

electronic charge $e = -1.602 \times 10^{-19} \text{ C}$.

Electric current is the time rate of change of charge, measured in amperes (A)

M
CU

$$i = \frac{dq}{dt} \quad (1.1)$$

where current is measured in amperes (A), and

$$1 \text{ ampere} = 1 \text{ coulomb/second}$$

The charge transferred between time t_0 and t is obtained by integrating both sides of Eq. (1.1). We obtain

A

$$q = \int_{t_0}^t i dt \quad (1.2)$$

direct current (dc) is a current that remains constant with time.



An **alternating current (ac)** is a current that varies sinusoidally with time.

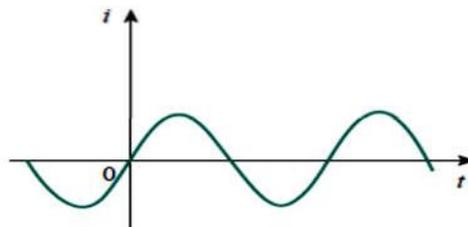

Example

The total charge entering a terminal is given by $q = 5t \sin 4\pi t$ mC. Calculate the current at $t = 0.5$ s.

Solution:

$$i = \frac{dq}{dt} = \frac{d}{dt}(5t \sin 4\pi t) \text{ mC/s} = (5 \sin 4\pi t + 20\pi t \cos 4\pi t) \text{ mA}$$

At $t = 0.5$,

$$i = 5 \sin 2\pi + 10\pi \cos 2\pi = 0 + 10\pi = 31.42 \text{ mA}$$

Practice Problem

If in Example 1.2, $q = (10 - 10e^{-2t})$ mC, find the current at $t = 0.5$ s.

Answer: 7.36 mA.

Example

Determine the total charge entering a terminal between $t = 1$ s and $t = 2$ s if the current passing the terminal is $i = (3t^2 - t)$ A.

Solution:

$$\begin{aligned} q &= \int_{t=1}^2 i dt = \int_1^2 (3t^2 - t) dt \\ &= \left(t^3 - \frac{t^2}{2} \right) \Big|_1^2 = (8 - 2) - \left(1 - \frac{1}{2} \right) = 5.5 \text{ C} \end{aligned}$$

Practice Problem

The current flowing through an element is

$$i = \begin{cases} 2 \text{ A}, & 0 < t < 1 \\ 2t^2 \text{ A}, & t > 1 \end{cases}$$

Calculate the charge entering the element from $t = 0$ to $t = 2$ s.

Answer: 6.667 C.

VOLTAGE

Voltage (or potential difference) is the energy required to move a unit charge through an element, measured in volts (V).

$$v_{ab} = \frac{dw}{dq}$$

where w is energy in joules (J) and q is charge in coulombs (C). The voltage v_{ab} or simply v is measured in volts (V)

$$1 \text{ volt} = 1 \text{ joule/coulomb} = 1 \text{ newton meter/coulomb}$$

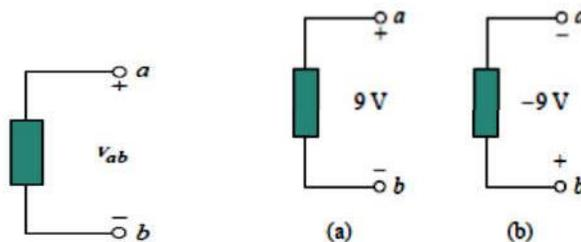

POWER AND ENERGY

Power is the time rate of expending or absorbing energy, measured in watts

We write this relationship as

$$p = \frac{dw}{dt} \quad (1.5)$$

where p is power in watts (W), w is energy in joules (J), and t is time in seconds (s). From Eqs. (1.1), (1.3), and (1.5), it follows that

$$p = \frac{dw}{dt} = \frac{dw}{dq} \cdot \frac{dq}{dt} = vi \quad (1.6)$$

or

$$p = vi \quad (1.7)$$

Passive sign convention is satisfied when the current enters through the positive terminal of an element and $p = +vi$. If the current enters through the negative terminal, $p = -vi$.

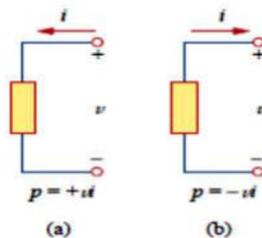

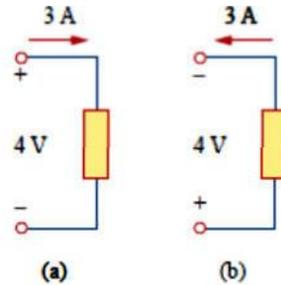

Two cases of an element with an absorbing power of 12 W: (a) $p = 4 \times 3 = 12$ W, (b) $p = 4 \times 3 = 12$ W.

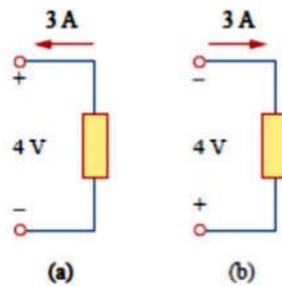

Two cases of an element with a supplying power of 12 W: (a) $p = -4 \times 3 = -12$ W, (b) $p = -4 \times 3 = -12$ W.

$$\sum p = 0$$

This again confirms the fact that the total power supplied to the circuit must balance the total power absorbed. the energy absorbed or supplied by an element from time t_0 to time t is

$$w = \int_{t_0}^t p \, dt = \int_{t_0}^t vi \, dt \quad (1.9)$$

Energy is the capacity to do work, measured in joules (J).

The electric power utility companies measure energy in watt-hours (Wh), where $1 \text{ Wh} = 3,600 \text{ J}$

Example

Find the power delivered to an element at $t = 3$ ms if the current entering its positive terminal is

$$i = 5 \cos 60\pi t \text{ A}$$

and the voltage is: (a) $v = 3i$, (b) $v = 3 di/dt$.

Solution:

(a) The voltage is $v = 3i = 15 \cos 60\pi t$; hence, the power is

$$p = vi = 75 \cos^2 60\pi t \text{ W}$$

At $t = 3$ ms,

$$p = 75 \cos^2(60\pi \times 3 \times 10^{-3}) = 75 \cos^2 0.18\pi = 53.48 \text{ W}$$

(b) We find the voltage and the power as

$$v = 3 \frac{di}{dt} = 3(-60\pi)5 \sin 60\pi t = -900\pi \sin 60\pi t \text{ V}$$

$$p = vi = -4500\pi \sin 60\pi t \cos 60\pi t \text{ W}$$

At $t = 3$ ms,

$$\begin{aligned} p &= -4500\pi \sin 0.18\pi \cos 0.18\pi \text{ W} \\ &= -14137.167 \sin 32.4^\circ \cos 32.4^\circ = -6.396 \text{ kW} \end{aligned}$$

Practice Problem

Find the power delivered to the element in Example 1.5 at $t = 5$ ms if the current remains the same but the voltage is: (a) $v = 2i$ V,

(b) $v = \left(10 + 5 \int_0^t i dt\right)$ V.

Answer: (a) 17.27 W, (b) 29.7 W.

Example

How much energy does a 100-W electric bulb consume in two hours?

Solution:

$$\begin{aligned} w &= pt = 100 \text{ (W)} \times 2 \text{ (h)} \times 60 \text{ (min/h)} \times 60 \text{ (s/min)} \\ &= 720,000 \text{ J} = 720 \text{ kJ} \end{aligned}$$

This is the same as

$$w = pt = 100 \text{ W} \times 2 \text{ h} = 200 \text{ Wh}$$

CIRCUITELEMENTS

An **electric circuit** is an interconnection of electrical element There are two types of elements found in electric circuits: *passive* elements and *active* elements. An active element is capable of generating energy while a passive element is not. Examples of passive elements are resistors, capacitors, and inductors. Typical active elements include generators, batteries, and operational amplifiers .An **ideal independent source** is an active element that provides a specified voltage or current that is completely independent of other circuit variables

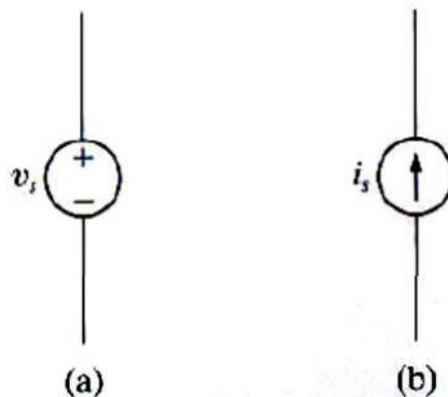

The circuit symbols for (a)an ideal independent source And (b)an ideal independent current source

An ideal dependent (or controlled) source is an active element in which the source quantity is controlled by another voltage or current.

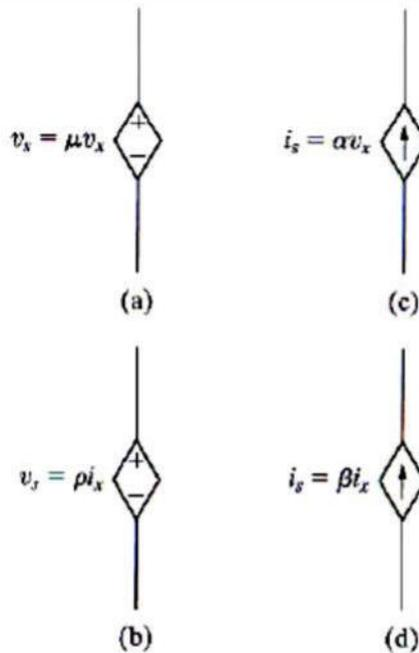

The circuit symbols for (a) an ideal dependent voltage-controlled voltage source, (b) an ideal dependent current-controlled voltage source, (c) an ideal dependent voltage-controlled current source, and (d) an ideal dependent current-controlled current source.

Dependent sources are useful in modeling elements such as transistors, operational amplifiers and integrated circuits. An example of a current controlled voltage source is shown on the right-hand side of Fig where the voltage $10i$ of the voltage source depends on the current I through element C . Students might be surprised that the value of the dependent voltage source is $10i$ V (and not $10i$ A) because it is a voltage source. The key idea to keep in mind is that a voltage source comes with polarities (+ -) in its symbol, while a current source comes with an arrow, irrespective of what it depends on

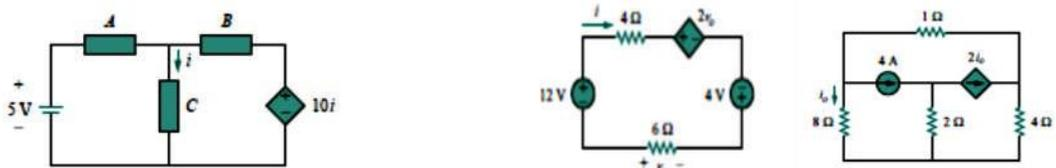

Example

.Calculate the power supplied or absorbed by each element in Fig

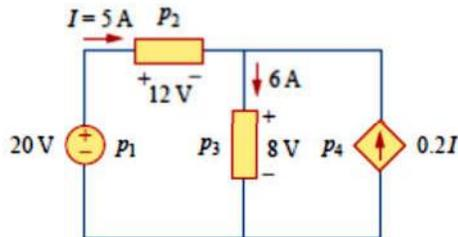

Solution:

We apply the sign convention for power For p_1 , the 5-A current is out of the positive terminal (or into the negative terminal); hence

$$p_1 = 20(-5) = -100 \text{ W} \quad \text{Supplied power}$$

For p_2 and p_3 , the current flows into the positive terminal of the element in each case.

$$p_2 = 12(5) = 60 \text{ W} \quad \text{Absorbed power}$$

$$p_3 = 8(6) = 48 \text{ W} \quad \text{Absorbed power}$$

For p_4 , we should note that the voltage is 8 V (positive at the top), the same as the voltage for p_3 , since both the passive element and the dependent source are connected to the same terminals. (Remember that voltage is always measured across an element in a circuit.) Since the current flows out of the positive terminal,

$$p_4 = 8(-0.2I) = 8(-0.2 \times 5) = -8 \text{ W} \quad \text{Supplied power}$$

We should observe that the 20-V independent voltage source and 0.2I dependent current source are supplying power to the rest of the network, while the two passive elements are absorbing power. Also,

$$p_1 + p_2 + p_3 + p_4 = -100 + 60 + 48 - 8 = 0$$

In agreement with Eq. (1.8), the total power supplied equals the total power absorbed.

Summary

1. An electric circuit consists of electrical elements connected together.
2. The International System of Units (SI) is the international measurement language, which enables engineers to communicate their results. From the six principal units, the units of other physical quantities can be derived.
3. Current is the rate of charge flow.

$$i = \frac{dq}{dt}$$

4. Voltage is the energy required to move 1 C of charge through an element.

$$v = \frac{dw}{dq}$$

5. Power is the energy supplied or absorbed per unit time. It is also the product of voltage and current.

$$p = \frac{dw}{dt} = vi$$

6. According to the passive sign convention, power assumes a positive sign when the current enters the positive polarity of the voltage across an element.
7. An ideal voltage source produces a specific potential difference across its terminals regardless of what is connected to it. An ideal current source produces a specific current through its terminals regardless of what is connected to it.
8. Voltage and current sources can be dependent or independent. A dependent source is one whose value depends on some other circuit variable.
9. Two areas of application of the concepts covered in this chapter are the TV picture tube and electricity billing procedure.

Fundamentals of Electric Circuits

First Semester

CHAPTER TWO

Basic Laws

Basic Laws

OHM'S LAW

Materials in general have a characteristic behavior of resisting the flow of electric charge. This physical property, or ability to resist current, is known as *resistance* and is represented by the symbol R . The resistance of any material with a uniform cross-sectional area A depends on A and its length l , as shown in Fig

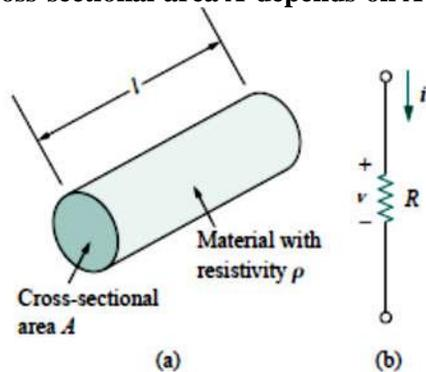

(a) Resistor, (b) Circuit symbol for resistance

$$R = \rho \frac{\ell}{A}$$

Where ρ is known as the *resistivity* of the material in ohm-meters. Good conductors, such as copper and aluminum, have low resistivities, while insulators, such as mica and paper, have high resistivities. Table 2.1 presents the values of ρ for some common materials and shows which materials are used for conductors, insulators, and semiconductors.

TABLE 2.1 Resistivities of common materials.

Material	Resistivity ($\Omega \cdot m$)	Usage
Silver	1.64×10^{-8}	Conductor
Copper	1.72×10^{-8}	Conductor
Aluminum	2.8×10^{-8}	Conductor
Gold	2.45×10^{-8}	Conductor
Carbon	4×10^{-5}	Semiconductor
Germanium	47×10^{-2}	Semiconductor
Silicon	6.4×10^2	Semiconductor
Paper	10^{10}	Insulator
Mica	5×10^{11}	Insulator
Glass	10^{12}	Insulator
Teflon	3×10^{12}	Insulator

Ohm's law states that the voltage v across a resistor is directly proportional to the current flowing through the resistor.

$$v = iR \quad v \propto i$$

The **resistance R** of an element denotes its ability to resist the flow of electric current; it is measured in ohms (Ω). Since the value of R can range from zero to infinity, it is important that we consider the two extreme possible values of R . An element with $R = 0$ is called a *short circuit*, as shown in Fig.(a)

.A **short circuit** is a circuit element with resistance approaching zero.

$$v = iR = 0$$

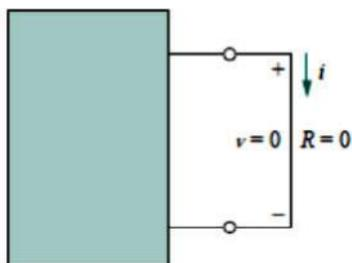

(a)

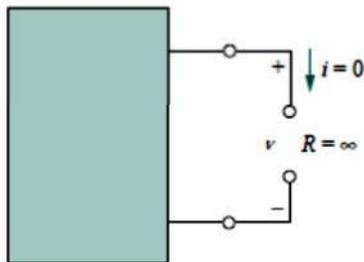

(b)

(a) Short circuit ($R = 0$),

(b) Open circuit ($R = \infty$).

An **open circuit** is a circuit element with resistance approaching infinity.

A useful quantity in circuit analysis is the reciprocal of resistance R , known as *conductance* and denoted by G :

$$G = \frac{1}{R} = \frac{i}{v}$$

The unit of conductance is the *mho* (ohm spelled backward) or reciprocal ohm, with symbol \mathcal{O} the inverted omega. Although engineers often use the mhos, in this book we prefer to use the Siemens (S), the SI unit of conductance

$$1 \text{ S} = 1 \mathcal{O} = 1 \text{ A/V}$$

Conductance is the ability of an element to conduct electric current; it is measured in mhos \mathcal{O} or Siemens (S).

The same resistance can be expressed in ohms or Siemens. For example, 10Ω is the same as 0.1 S .

$$i = Gv$$

The power dissipated by a resistor can be expressed in terms of R . Using

$$p = vi = i^2 R = \frac{v^2}{R}$$

The power in terms of G

$$p = vi = v^2 G = \frac{i^2}{G}$$

1. The power dissipated in a resistor is a nonlinear function of either current or voltage.
2. Since R and G are positive quantities, the power dissipated in a resistor is always positive. Thus, a resistor always absorbs power from the circuit. This confirms the idea that a resistor is a passive element, incapable of generating energy

Example

An electric iron draws 2 A at 120 V . Find its resistance.

Solution:

From Ohm's law,

$$R = \frac{v}{i} = \frac{120}{2} = 60 \Omega$$

Practice Problem

The essential component of a toaster is an electrical element (a resistor) that converts electrical energy to heat energy. How much current is drawn by a toaster with resistance 15Ω at 110 V ?

Answer: 7.333 A.

Example

In the circuit shown in Fig. 2.8, calculate the current i , the conductance G , and the power p .

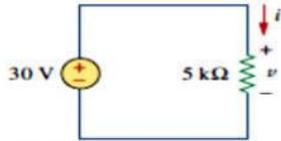

Solution:

The voltage across the resistor is the same as the source voltage (30 V) because the resistor and the voltage source are connected to the same pair of terminals. Hence, the current is

$$i = \frac{v}{R} = \frac{30}{5 \times 10^3} = 6 \text{ mA}$$

The conductance is

$$G = \frac{1}{R} = \frac{1}{5 \times 10^3} = 0.2 \text{ mS}$$

We can calculate the power in various ways using either Eqs. (1.7), (2.10), or (2.11).

$$p = vi = 30(6 \times 10^{-3}) = 180 \text{ mW}$$

or

$$p = i^2R = (6 \times 10^{-3})^2 5 \times 10^3 = 180 \text{ mW}$$

or

$$p = v^2G = (30)^2 0.2 \times 10^{-3} = 180 \text{ mW}$$

Practice Problem

For the circuit shown in Fig., calculate the voltage v , the conductance G , and the power p

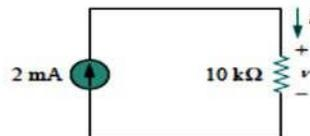

Example

A voltage source of $20 \sin \pi t$ V is connected across a $5\text{-k}\Omega$ resistor. Find the current through the resistor and the power dissipated.

Solution:

$$i = \frac{v}{R} = \frac{20 \sin \pi t}{5 \times 10^3} = 4 \sin \pi t \text{ mA}$$

Hence,

$$p = vi = 80 \sin^2 \pi t \text{ mW}$$

NODES, BRANCHES, AND LOOPS

A branch represents a single element such as a voltage source or a resistor.

In other words, a branch represents any two-terminal element. The circuit in Fig. has five branches, namely, the 10-V voltage source, the 2-A current source, and the three resistors.

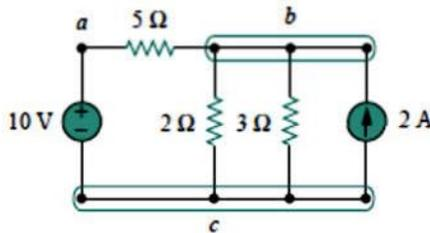
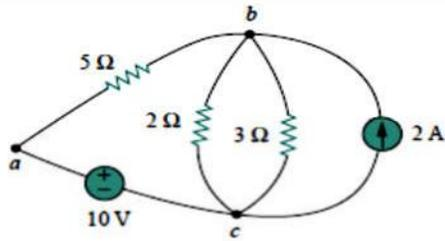

Figure.1 Nodes, branches, and loops.

A node is the point of connection between two or more branches.

A node is usually indicated by a dot in a circuit. If a short circuit (a connecting wire) connects two nodes, the two nodes constitute a single node. The circuit in Fig. 1 has three nodes *a*, *b*, and *c*. Notice that the three points that form node *b* are connected by perfectly conducting wires and therefore constitute a single point. The same is true of the four points forming node *c*. We demonstrate that the circuit in Fig. 1 has only three nodes by redrawing the circuit in Fig. 2.



The three-node circuit of Fig. 2, is redrawn

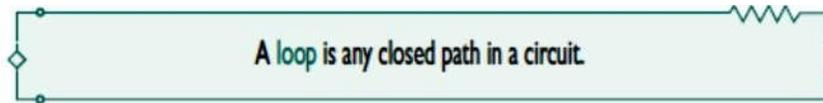

A loop is a closed path formed by starting at a node, passing through a set of nodes, and returning to the starting node. A network with b branches, n nodes, and l independent loops will satisfy the fundamental theorem of network topology

$$b = l + n - 1$$

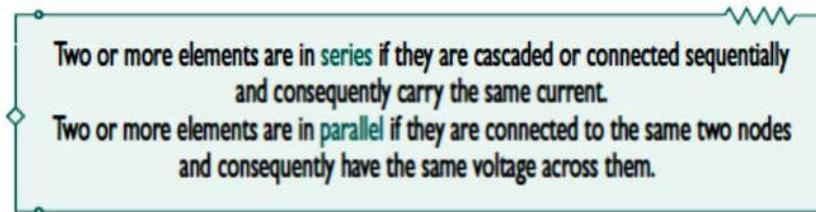

Example

Determine the number of branches and nodes in the circuit shown in Fig. 3. Identify which elements are in series and which are in parallel.

Solution:

Since there are four elements in the circuit, the circuit has four branches: 10 V, 5 Ω, 6 Ω, and 2 A. The circuit has three nodes as identified in Fig. 3. The 5Ω resistor is in series with the 10-V voltage source because the same current would flow in both. The 6Ω resistor is in parallel with the 2-A current source because both are connected to the same nodes 2 and 3.

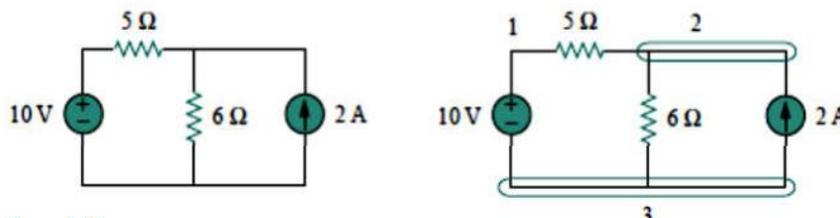

(3) The three nodes in the circuit

KIRCHHOFF'S LAWS

Kirchhoff's current law (KCL) and Kirchhoff's voltage law (KVL).

Kirchhoff's current law (KCL) states that the algebraic sum of currents entering a node (or a closed boundary) is zero.

Mathematically, KCL implies that

$$\sum_{n=1}^N i_n = 0$$

Where N is the number of branches connected to the node and i_n is n th current entering (or leaving) the node. By this law, currents entering node may be regarded as positive, while currents leaving the node maybe taken as negative or vice versa Consider the node in Fig.4. Applying KCL gives

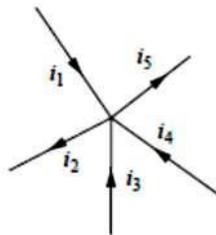

(4) Currents at a node illustrating KCL.

$$i_1 + (-i_2) + i_3 + i_4 + (-i_5) = 0$$

$$i_1 + i_3 + i_4 = i_2 + i_5$$

The sum of the currents entering a node is equal to the sum of the currents leaving the node.

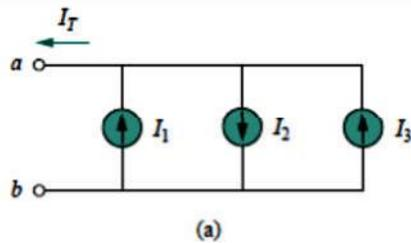

$$I_T = I_1 - I_2 + I_3$$

Kirchhoff's voltage law (KVL) states that the algebraic sum of all voltages around a closed path (or loop) is zero.

Expressed mathematically, KVL states that

$$\sum_{m=1}^M v_m = 0$$

Where M is the number of voltages in the loop (or the number of branches in the loop) and v_m is the m th voltage

The sign on each voltage is the polarity of the terminal encountered first as we travel around the loop. We can start with any branch and go around the loop either clockwise or counterclockwise. Suppose we start with the voltage source and go clockwise around the loop as shown; then voltages would be $-v_1, +v_2, +v_3, -v_4,$ and $+v_5$, in that order. For example, as we reach branch 3, the positive terminal is met first; hence we have $+v_3$. For branch 4, we reach the negative terminal first; hence, $-v_4$. Thus, KVL yields

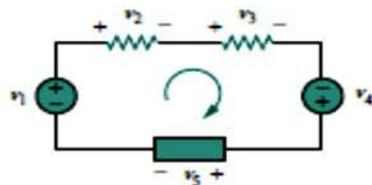

$$-v_1 + v_2 + v_3 - v_4 + v_5 = 0$$

Rearranging terms gives

$$v_2 + v_3 + v_5 = v_1 + v_4$$

which may be interpreted as

$$\text{Sum of voltage drops} = \text{Sum of voltage rises}$$

When voltage sources are connected in series, KVL can be applied to obtain the total voltage. The combined voltage is the algebraic sum of the voltages of the individual sources. For example, for the voltage sources shown in Fig. 2.20(a), the combined or equivalent voltage source in Fig. 2.20(b) is obtained by applying KVL.

$$-V_{ab} + V_1 + V_2 - V_3 = 0$$

or

$$V_{ab} = V_1 + V_2 - V_3 \quad (2.23)$$

To avoid violating KVL, a circuit cannot contain two different voltages V_1 and V_2 in parallel unless $V_1 = V_2$.

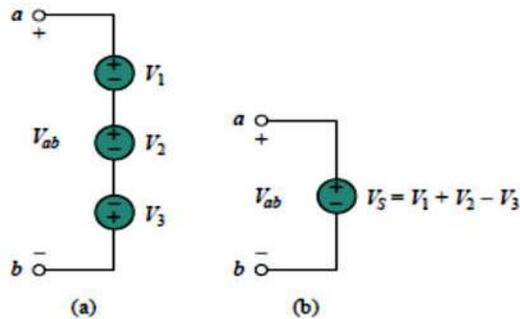

Voltage sources in series:
(a) original circuit, (b) equivalent circuit.

Example

For the circuit in Fig. 2.21(a), find voltages v_1 and v_2 .

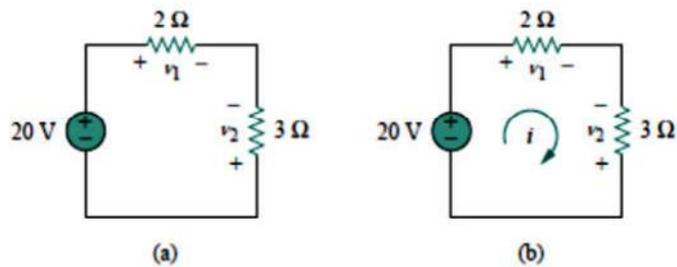

Figure 2.21 For Example 2.5.

Solution:

To find v_1 and v_2 , we apply Ohm's law and Kirchhoff's voltage law. Assume that current i flows through the loop as shown in Fig. 2.21(b). From Ohm's law,

$$v_1 = 2i, \quad v_2 = -3i \quad (2.5.1)$$

Applying KVL around the loop gives

$$-20 + v_1 - v_2 = 0 \quad (2.5.2)$$

Substituting Eq. (2.5.1) into Eq. (2.5.2), we obtain

$$-20 + 2i + 3i = 0 \quad \text{or} \quad 5i = 20 \quad \Rightarrow \quad i = 4 \text{ A}$$

Substituting i in Eq. (2.5.1) finally gives

$$v_1 = 8 \text{ V}, \quad v_2 = -12 \text{ V}$$

Practice Problem

Find v_1 and v_2 in the circuit of Fig

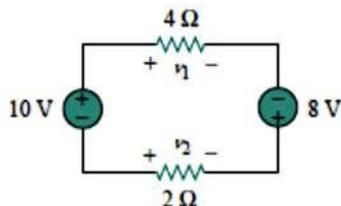

Answer: 12 V, -6 V.

Example

Determine v_o and i in the circuit shown in Fig

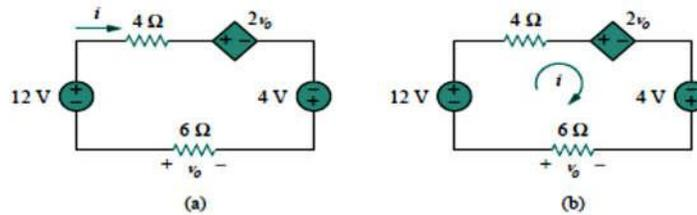

Solution:

We apply KVL around the loop as shown in Fig

$$-12 + 4i + 2v_o - 4 + 6i = 0$$

Applying Ohm's law to the 6-Ω resistor gives

$$v_o = -6i$$

Substituting Eq. (2.6.2) into Eq. (2.6.1) yields

$$-16 + 10i - 12i = 0 \quad \Rightarrow \quad i = -8 \text{ A}$$

and $v_o = 48 \text{ V}$.

Practice Problem

Find v_x and v_o in the circuit of

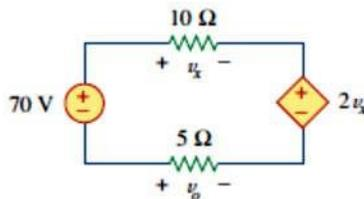

Answer: 20 V, -10 V.

Example

Find current i_o and voltage v_o in the circuit shown in Fig.

Solution:

Applying KCL to node a , we obtain

$$3 + 0.5i_o = i_o \implies i_o = 6 \text{ A}$$

For the $4\text{-}\Omega$ resistor, Ohm's law gives

$$v_o = 4i_o = 24 \text{ V}$$

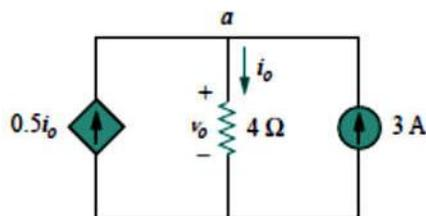

Practice Problem

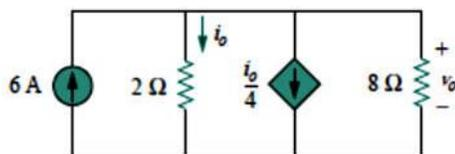

Find v_o and i_o in the circuit of Fig..

Answer: 8 V, 4 A.

Example

Find the currents and voltages in the circuit shown in Fig

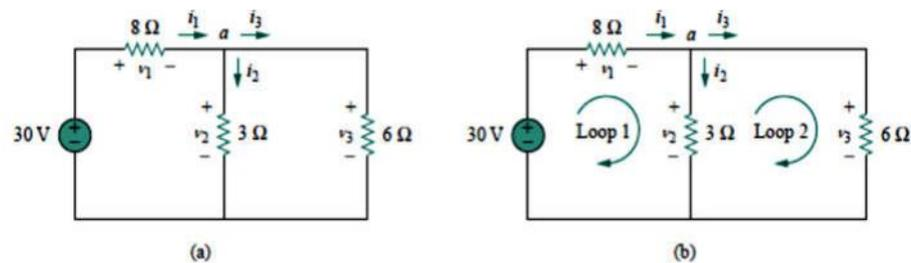

Solution:

We apply Ohm's law and Kirchhoff's laws. By Ohm's law:

$$v_1 = 8i_1, \quad v_2 = 3i_2, \quad v_3 = 6i_3$$

Since the voltage and current of each resistor are related by Ohm's law as shown, we are really looking for three things: (v_1, v_2, v_3) or (i_1, i_2, i_3) . At node a , KCL gives

$$i_1 - i_2 - i_3 = 0$$

Applying KVL to loop 1 as in Fig. 2.27(b),

$$-30 + v_1 + v_2 = 0$$

We express this in terms of i_1 and i_2

$$-30 + 8i_1 + 3i_2 = 0$$

or

$$i_1 = \frac{(30 - 3i_2)}{8}$$

Applying KVL to loop 2,

$$-v_2 + v_3 = 0 \quad \Rightarrow \quad v_3 = v_2$$

as expected since the two resistors are in parallel. We express v_1 and v_2 in terms of i_1 and i_2

$$6i_3 = 3i_2 \quad \Rightarrow \quad i_3 = \frac{i_2}{2}$$

Substituting Eqs. (2.8.3) and (2.8.5) into (2.8.2) gives

$$\frac{30 - 3i_2}{8} - i_2 - \frac{i_2}{2} = 0$$

$$i_1 = 3 \text{ A}, \quad i_3 = 1 \text{ A}, \quad v_1 = 24 \text{ V}, \quad v_2 = 6 \text{ V}, \quad v_3 = 6 \text{ V}$$

Practice Problem

Find the currents and voltages in the circuit shown in Fig

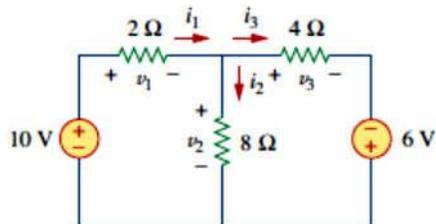

Answer: $v_1 = 6 \text{ V}$, $v_2 = 4 \text{ V}$, $v_3 = 10 \text{ V}$, $i_1 = 3 \text{ A}$, $i_2 = 500 \text{ mA}$, $i_3 = 1.25 \text{ A}$.

SERIES RESISTORS AND VOLTAGE DIVISION

The two resistors are in series, since the same current I flows in both of them. Applying Ohm's law to each of the resistors, we obtain

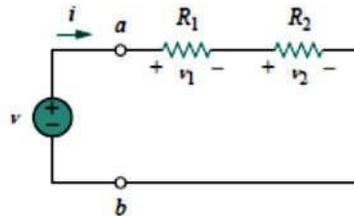

$$v_1 = iR_1, v_2 = iR_2 \text{ fig 6}$$

If we apply KVL to the loop (moving in the clockwise direction), we have

$$-v + v_1 + v_2 = 0$$

$$v = v_1 + v_2 = i(R_1 + R_2)$$

$$i = \frac{v}{R_1 + R_2}$$

$$v = i R_{\text{eq}} \quad R_{\text{eq}} = R_1 + R_2$$

$$R_{\text{eq}} = R_1 + R_2 + \dots + R_N$$

The equivalent resistance of any number of resistors connected in series is the sum of the individual resistances.

To determine the voltage across each resistor in Fig 6

$$v_1 = \frac{R_1}{R_1 + R_2} v, \quad v_2 = \frac{R_2}{R_1 + R_2} v$$

PARALLEL RESISTORS AND CURRENT DIVISION

Consider the circuit in Fig. where two resistors are connected in parallel and therefore have the same voltage across them. From Ohm's law,

$$v = i_1 R_1 = i_2 R_2$$

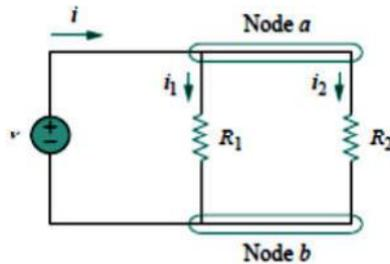

Two resistors in parallel.

$$i_1 = \frac{v}{R_1}, \quad i_2 = \frac{v}{R_2}$$

Applying KCL at node a gives the total current i as

$$i = i_1 + i_2$$

Substituting Eq. (2.33) into Eq. (2.34), we get

$$i = \frac{v}{R_1} + \frac{v}{R_2} = v \left(\frac{1}{R_1} + \frac{1}{R_2} \right) = \frac{v}{R_{\text{eq}}}$$

where R_{eq} is the equivalent resistance of the resistors in parallel:

$$\frac{1}{R_{\text{eq}}} = \frac{1}{R_1} + \frac{1}{R_2}$$

or

$$\frac{1}{R_{\text{eq}}} = \frac{R_1 + R_2}{R_1 R_2}$$

or

$$R_{\text{eq}} = \frac{R_1 R_2}{R_1 + R_2}$$

The equivalent resistance of two parallel resistors is equal to the product of their resistances divided by their sum.

with N resistors in parallel. The equivalent resistance is

$$\frac{1}{R_{\text{eq}}} = \frac{1}{R_1} + \frac{1}{R_2} + \cdots + \frac{1}{R_N}$$

Note that R_{eq} is always smaller than the resistance of the smallest resistor in the parallel combination. If $R_1 = R_2 = \cdots = R_N = R$, then

$$R_{\text{eq}} = \frac{R}{N}$$

For example, if four $100\text{-}\Omega$ resistors are connected in parallel, their equivalent resistance is $25\ \Omega$.

It is often more convenient to use conductance rather than resistance when dealing with resistors in parallel. The equivalent conductance for N resistors in parallel is

$$G_{\text{eq}} = G_1 + G_2 + G_3 + \cdots + G_N$$

Where $G_{\text{eq}} = 1/R_{\text{eq}}, G_1 = 1/R_1, G_2 = 1/R_2, G_3 = 1/R_3, \dots, G_N = 1/R_N$

The equivalent conductance of resistors connected in parallel is the sum of their individual conductances.

Given the total current I entering node a in how do we obtain current i_1 and i_2 ? We know that the equivalent resistor has the same voltage, or

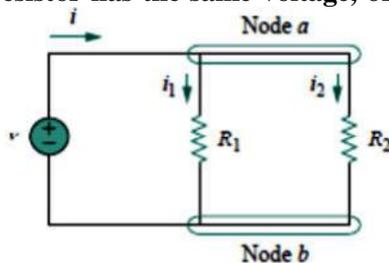

$$v = i R_{\text{eq}} = \frac{i R_1 R_2}{R_1 + R_2}$$

$$i_1 = \frac{R_2 i}{R_1 + R_2}, \quad i_2 = \frac{R_1 i}{R_1 + R_2}$$

As an extreme case, suppose one of the resistors is zero, say $R_2 = 0$; that is, R_2 is a short circuit, as shown in Fig8(a). $R_2 = 0$ implies that $i_1 = 0$, $i_2 = i$. This means that the entire current i bypasses R_1 and flows through the short circuit $R_2 = 0$, the path of least resistance. Thus when a circuit is short circuited, as shown in Fig8(a), two things should be kept in mind:

1. The equivalent resistance $R_{eq} = 0$. [See what happens when $R_2 = 0$
2. The entire current flows through the short circuit.

As another extreme case, suppose $R_2 = \infty$, that is, R_2 is an open circuit, as shown in Fig. 2.33(b). The current still flows through the path of least resistance, R_1 . By taking the limit of Eq. (2.37) as $R_2 \rightarrow \infty$, we obtain $R_{eq} = R_1$ in this case

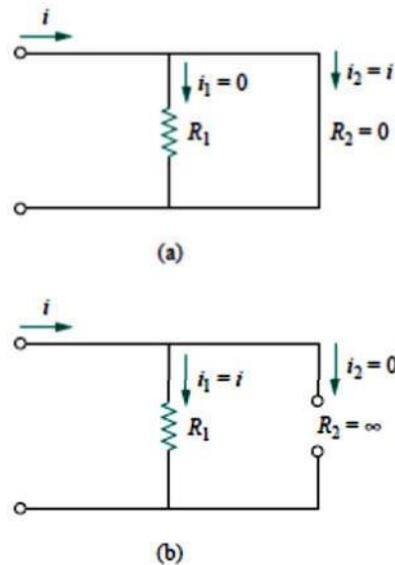

Fig 8

(a) A shorted circuit,
(b) an open circuit.

Example

Find R_{eq} for the circuit shown in Fig

Solution

To get R_{eq} , we combine resistors in series and in parallel. The 6- Ω and 3- Ω resistors are in parallel, so their equivalent resistance is

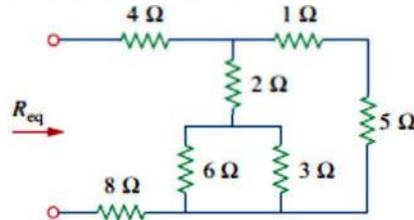

$$6 \Omega \parallel 3 \Omega = \frac{6 \times 3}{6 + 3} = 2 \Omega$$

(The symbol \parallel is used to indicate a parallel combination.) Also, the 1- Ω and 5- Ω resistors are in series; hence their equivalent resistance is

$$1 \Omega + 5 \Omega = 6 \Omega$$

Thus the circuit in Fig 1 is reduced to that in Fig. 2 (a). In Fig. 2. (a), we notice that the two 2- Ω resistors are in series, so the equivalent resistance is

$$2 \Omega + 2 \Omega = 4 \Omega$$

This 4- Ω resistor is now in parallel with the 6- resistor in Fig. 2.(a); their equivalent

$$4 \Omega \parallel 6 \Omega = \frac{4 \times 6}{4 + 6} = 2.4 \Omega$$

resistance

The circuit in Fig 2. (a) is now replaced with that in Fig. 2. (b). In Fig. 2. (b), the three resistors are in series. Hence, the equivalent resistance for the circuit is

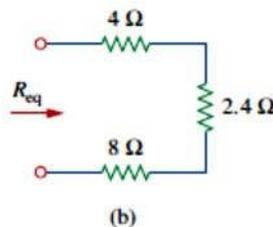
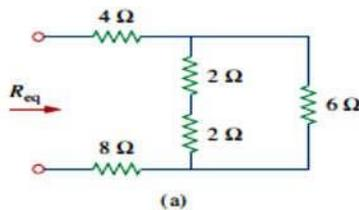
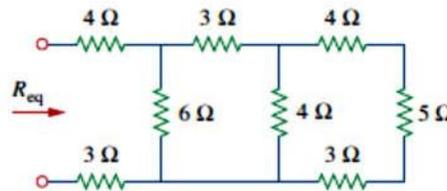

Fig 2

Practice Problem

By combining the resistors in Fig., find Req

. Answer: 10Ω



Example

Calculate the equivalent resistance R_{ab} in the circuit in Fig

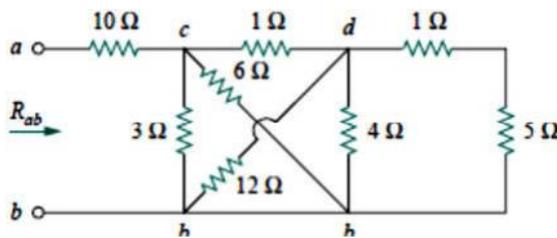

Solution:

The 3-Ω and 6-Ω resistors are in parallel because they are connected to the same two nodes c and b . Their combined resistance is

$$3 \Omega \parallel 6 \Omega = \frac{3 \times 6}{3 + 6} = 2 \Omega$$

Similarly, the 12- a Ω and 4- Ω resistors are in parallel since they are connected to the same two nodes d and b . Hence

$$12 \Omega \parallel 4 \Omega = \frac{12 \times 4}{12 + 4} = 3 \Omega$$

Also the 1- Ω and 5- Ω resistors are in series; hence, their equivalent resistance is

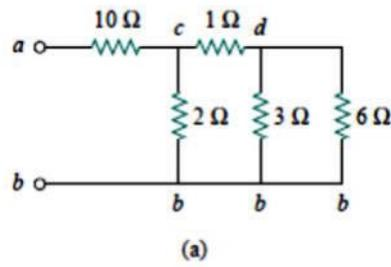

$$1 \Omega + 5 \Omega = 6 \Omega$$

$$2 \Omega \parallel 3 \Omega = \frac{2 \times 3}{2 + 3} = 1.2 \Omega$$

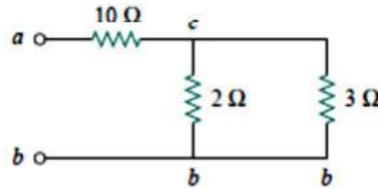

This 1.2-Ω resistor is in series with the 10-Ω resistor, so that

$$R_{ab} = 10 + 1.2 = 11.2 \Omega$$

Practice Problem

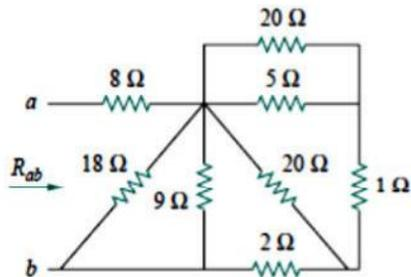

Find R_{ab} for the circuit in Fig.

Answer: 11 Ω.

Example

Find the equivalent conductance G_{eq} for the circuit in Fig

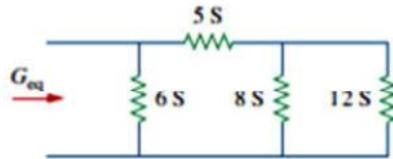

Solution:

The 8-S and 12-S resistors are in parallel, so their conductance is

$$8 \text{ S} + 12 \text{ S} = 20 \text{ S}$$

This 20-S resistor is now in series with 5 S as shown in Fig so that the combined conductance is

$$\frac{20 \times 5}{20 + 5} = 4 \text{ S}$$

This is in parallel with the 6-S resistor. Hence,

$$G_{eq} = 6 + 4 = 10 \text{ S}$$

We should note that the circuit in Fig. 2. (a) is the same as that in Fig. 2. (c). While the resistors in Fig. 2. (a) are expressed in siemens, those in Fig. 2. (c) are expressed in ohms. To show that the circuits are the same, we find for the circuit in Fig. 2. (c).

$$R_{eq} = \frac{1}{6} \parallel \left(\frac{1}{5} + \frac{1}{8} \parallel \frac{1}{12} \right) = \frac{1}{6} \parallel \left(\frac{1}{5} + \frac{1}{20} \right) = \frac{1}{6} \parallel \frac{1}{4}$$

$$= \frac{\frac{1}{6} \times \frac{1}{4}}{\frac{1}{6} + \frac{1}{4}} = \frac{1}{10} \Omega$$

$$G_{eq} = \frac{1}{R_{eq}} = 10 \text{ S}$$

This is the same as we obtained previously.

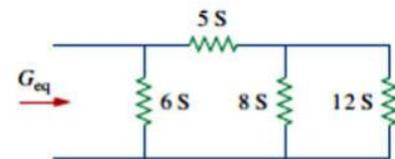

(a)

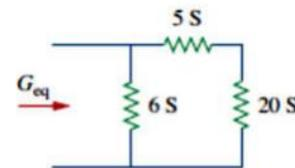

(b)

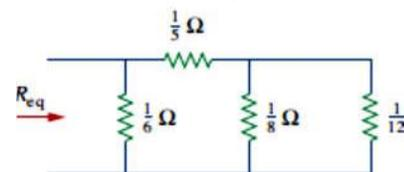

(c)

Practice Problem

Calculate G_{eq} in the circuit of Fig

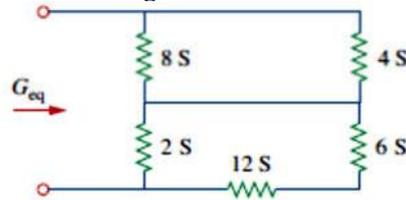

Answer: 4 S.

Example

Find i_o and v_o in the circuit shown in Fig. Calculate the power dissipated in the 3Ω resistor

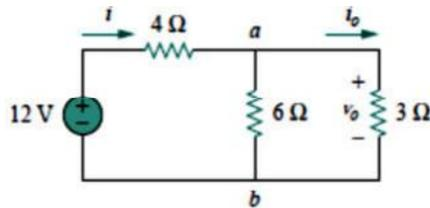

Solution:

The 6-Ω and 3-Ω resistors are in parallel, so their combined resistance is

$$6\ \Omega \parallel 3\ \Omega = \frac{6 \times 3}{6 + 3} = 2\ \Omega$$

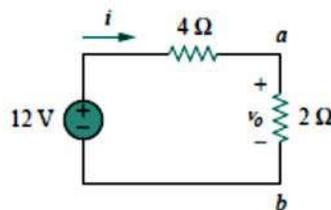

$$i = \frac{12}{4 + 2} = 2\ \text{A}$$

$$v_o = 2i = 2 \times 2 = 4\ \text{V.}$$

Or

$$v_o = \frac{2}{2 + 4}(12\ \text{V}) = 4\ \text{V} \quad v_o = 3i_o = 4 \quad \Rightarrow \quad i_o = \frac{4}{3}\ \text{A}$$

Another approach is to apply current division to the circuit in Fig. now that we know i , by writing

$$i_o = \frac{6}{6+3}i = \frac{2}{3}(2 \text{ A}) = \frac{4}{3} \text{ A}$$

The power dissipated in the 3- Ω resistor is

$$p_o = v_o i_o = 4 \left(\frac{4}{3} \right) = 5.333 \text{ W}$$

Practice Problem

Find v_1 and v_2 in the circuit shown Also calculate i_1 and i_2 and the power dissipated in the 12- Ω and 40- Ω resistors

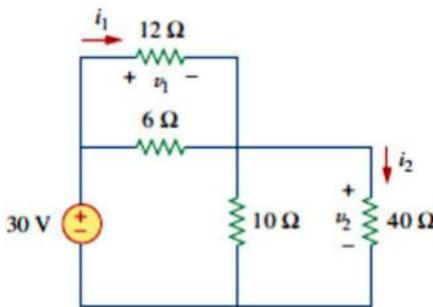

Answer: $v_1 = 10 \text{ V}$, $i_1 = 833.3 \text{ mA}$, $p_1 = 8.333 \text{ W}$, $v_2 = 20 \text{ V}$, $i_2 = 500 \text{ mA}$, $p_2 = 10 \text{ W}$.

Example

For the circuit shown in Fig. determine: (a) the voltage v_o , (b) the power supplied by the current source, (c) the power absorbed by each resistor

Solution:

(a) The 6-k Ω and 12-k Ω resistors are in series so that their combined value is $6 + 12 = 18 \text{ k}\Omega$. Thus the circuit in Fig. 2.44(a) reduces to that shown. We now apply the current division technique

to find i_1 and i_2 .

$$i_1 = \frac{18,000}{9,000 + 18,000} (30 \text{ mA}) = 20 \text{ mA}$$

$$i_2 = \frac{9,000}{9,000 + 18,000} (30 \text{ mA}) = 10 \text{ mA}$$

The Y and Δ networks are said to be *balanced* when

$$R_1 = R_2 = R_3 = R_Y, \quad R_a = R_b = R_c = R_\Delta$$

Under these conditions, conversion formulas become

$$R_Y = \frac{R_\Delta}{3} \quad \text{or} \quad R_\Delta = 3R_Y$$

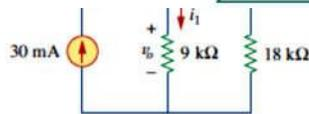

b

$$p = i_1^2 R = (10 \times 10^{-3})^2 (6,000) = 0.6 \text{ W}$$

Power absorbed by the 9-k Ω resistor is

$$p = \frac{v_o^2}{R} = \frac{(180)^2}{9,000} = 3.6 \text{ W}$$

or

$$p = v_o i_1 = 180(20) \text{ mW} = 3.6 \text{ W}$$

Notice that the power supplied (5.4 W) equals the power absorbed (1.2 + 0.6 + 3.6 = 5.4 W). This is one way of checking results.

Practice Problem

For the circuit shown, find: (a) v_1 and v_2 , (b) the power dissipated in the 3 k Ω and 20 k Ω resistors, and (c) the power supplied by the current source

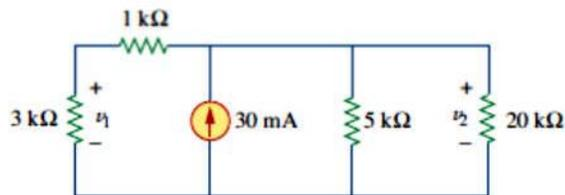

Answer: (a) 45 V, 60 V, (b) 675 mW, 180 mW, (c) 1.8 W.

WYE-DELTA TRANSFORMATIONS

Situations often arise in circuit analysis when the resistors are neither in parallel nor in series. For example, consider the bridge circuit in Fig. 1. How do we combine resistors R_1 through R_6 when the resistors are neither in series nor in parallel? Many circuits of the type shown in Fig. 1 can be simplified by using three-terminal equivalent networks. These are

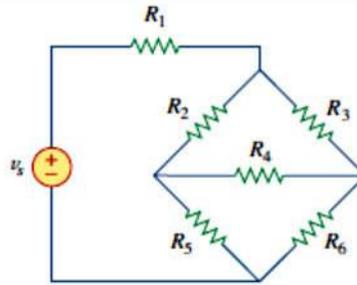

Fig 1

the wye (Y) or tee (T) network shown in Fig. 2. and the delta (Δ) or pi (π) network shown in Fig. 3. These networks occur by themselves or as part of a larger network. They are used in three-phase networks, electrical filters, and matching networks. Our main interest here is in how to identify them when they occur as part of a network and how to apply wye-delta transformation in the analysis of that network

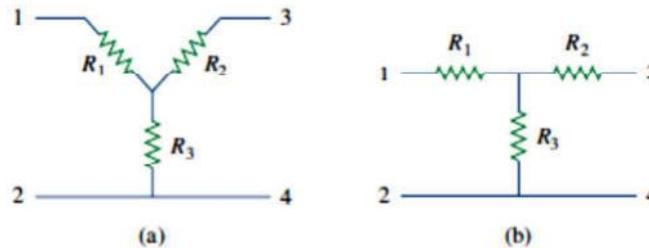

Fig 2. Two forms of the same network: (a) Y, (b) T.



Fig 3 .Two forms of the same network: (a) Δ (b) π

Delta to Wye Conversion

$$R_1 = \frac{R_b R_c}{R_a + R_b + R_c}$$

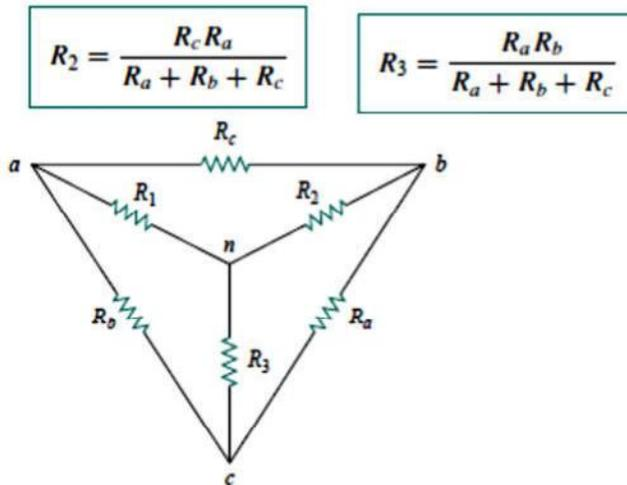

Each resistor in the Y network is the product of the resistors in the two adjacent Δ branches, divided by the sum of the three Δ resistors.

Wye to Delta Conversion

To obtain the conversion formulas for transforming a wye network to an equivalent delta network, we note from Eqs

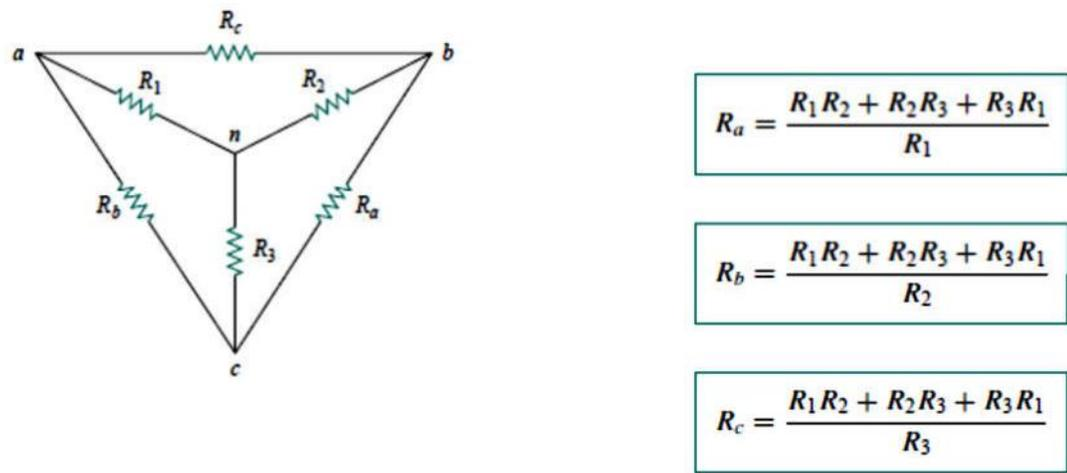

Each resistor in the Δ network is the sum of all possible products of Y resistors taken two at a time, divided by the opposite Y resistor.

Example

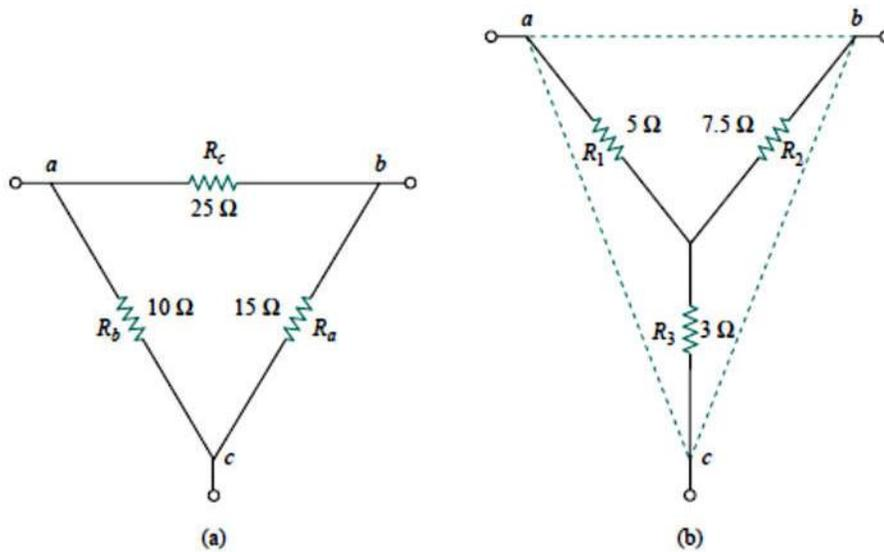

(a) original network, (b) Y equivalent network

Solution:

$$R_1 = \frac{R_b R_c}{R_a + R_b + R_c} = \frac{25 \times 10}{25 + 10 + 15} = \frac{250}{50} = 5 \Omega$$

$$R_2 = \frac{R_c R_a}{R_a + R_b + R_c} = \frac{25 \times 15}{50} = 7.5 \Omega$$

$$R_3 = \frac{R_a R_b}{R_a + R_b + R_c} = \frac{15 \times 10}{50} = 3 \Omega$$

Practice Problem

Transform the wye network to a delta network.

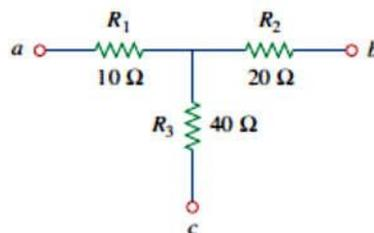

Answer: $R_a = 140 \Omega$, $R_b = 70 \Omega$, $R_c = 35 \Omega$.

Example

Obtain the equivalent resistance R_{ab} for the circuit in Fig and use it to find current i .

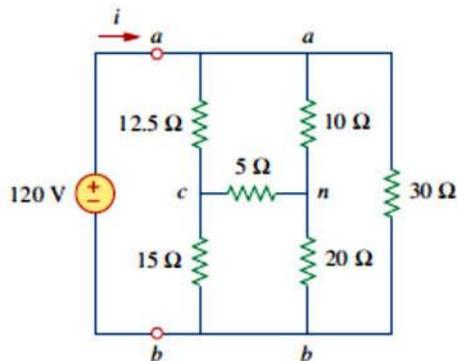

Attempt. In this circuit, there are two Y networks and three Δ networks. Transforming just one of these will simplify the circuit. If we convert the Y network comprising the 5- Ω , 10- Ω , and 20- Ω resistors, we may select

$$R_1 = 10 \Omega, \quad R_2 = 20 \Omega, \quad R_3 = 5 \Omega$$

Thus from Eqs. (2.53) to (2.55) we have

$$R_a = \frac{R_1 R_2 + R_2 R_3 + R_3 R_1}{R_1} = \frac{10 \times 20 + 20 \times 5 + 5 \times 10}{10}$$

$$= \frac{350}{10} = 35 \Omega$$

$$R_b = \frac{R_1 R_2 + R_2 R_3 + R_3 R_1}{R_2} = \frac{350}{20} = 17.5 \Omega$$

$$R_c = \frac{R_1 R_2 + R_2 R_3 + R_3 R_1}{R_3} = \frac{350}{5} = 70 \Omega$$

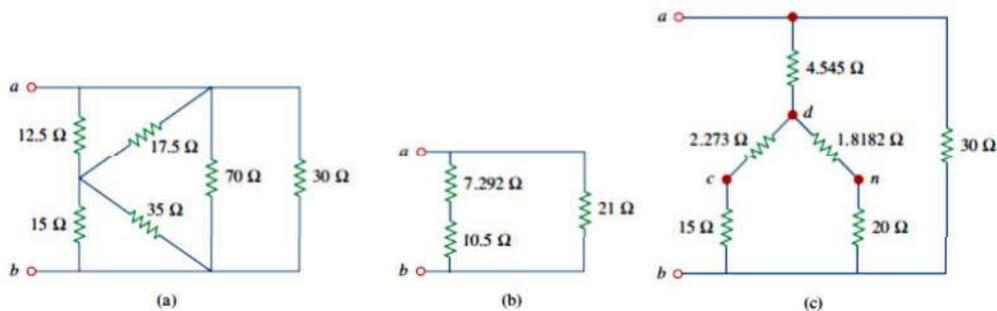

Fig 4

Equivalent circuits with the voltage source removed.

With the Y converted Δ to the equivalent circuit (with the voltage source removed for now) is shown in Fig. 4 (a). Combining the three pairs of resistors in parallel, we obtain

$$\begin{aligned}70 \parallel 30 &= \frac{70 \times 30}{70 + 30} = 21 \Omega \\12.5 \parallel 17.5 &= \frac{12.5 \times 17.5}{12.5 + 17.5} = 7.292 \Omega \\15 \parallel 35 &= \frac{15 \times 35}{15 + 35} = 10.5 \Omega\end{aligned}$$

So that the equivalent circuit is shown in Fig. 4 (b). Hence, we find

We observe that we have successfully solved the problem.

Now we must evaluate the solution.

. Evaluate. Now we must determine if the answer is correct and then evaluate the final solution.

It is relatively easy to check the answer; we do this by solving the problem starting with a delta-*can* transformation. Let us transform the delta, *can*, into a wye.

Let $R_c = 10 \Omega$, $R_a = 5 \Omega$, and $R_n = 12.5 \Omega$. This will lead to (let d represent the middle of the wye):

$$\begin{aligned}R_{ad} &= \frac{R_c R_n}{R_a + R_c + R_n} = \frac{10 \times 12.5}{5 + 10 + 12.5} = 4.545 \Omega \\R_{cd} &= \frac{R_a R_n}{27.5} = \frac{5 \times 12.5}{27.5} = 2.273 \Omega \\R_{nd} &= \frac{R_a R_c}{27.5} = \frac{5 \times 10}{27.5} = 1.8182 \Omega\end{aligned}$$

This now leads to the circuit shown in Figure 2.53(c). Looking at the resistance between d and b , we have two series combination in parallel, giving us

$$R_{db} = \frac{(2.273 + 15)(1.8182 + 20)}{2.273 + 15 + 1.8182 + 20} = \frac{376.9}{39.09} = 9.642 \Omega$$

This is in series with the $4.545\text{-}\Omega$ resistor, both of which are in parallel with the $30\text{-}\Omega$ resistor. This then gives us the equivalent resistance of the circuit.

$$R_{ab} = \frac{(9.642 + 4.545)30}{9.642 + 4.545 + 30} = \frac{425.6}{44.19} = 9.631 \Omega$$

This now leads to

$$i = \frac{v_s}{R_{ab}} = \frac{120}{9.631} = 12.46 \text{ A}$$

We note that using two variations on the wye-delta transformation leads to the same results. This represents a very good check.

- **Satisfactory?** Since we have found the desired answer by determining the equivalent resistance of the circuit first and the answer checks, then we clearly have a satisfactory solution. This represents what can be presented to the individual assigning the problem.

Practice Problem

For the bridge network in Fig find R_{ab} and i .

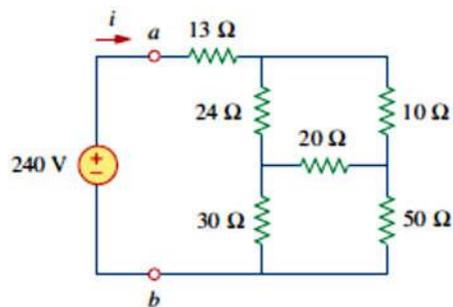

{ Answer: 40Ω , 6 A . }

Fundamentals of Electric Circuits

First Semester

CHAPTER THREE

METHODS OF ANALYSIS

METHODS OF ANALYSIS

Nodal analysis

In *nodal analysis*, we are interested in finding the node voltages. Given a circuit with n nodes without voltage sources, the nodal analysis of the circuit involves taking the following three steps

Steps to Determine Node Voltages:

1. Select a node as the reference node. Assign voltages v_1, v_2, \dots, v_{n-1} to the remaining $n - 1$ nodes. The voltages are referenced with respect to the reference node.
2. Apply KCL to each of the $n - 1$ nonreference nodes. Use Ohm's law to express the branch currents in terms of node voltages.
3. Solve the resulting simultaneous equations to obtain the unknown node voltages.

Current flows from a higher potential to a lower potential in a resistor.

We can express this principle as

$$i = \frac{v_{\text{higher}} - v_{\text{lower}}}{R}$$

node 1, applying KCL gives

$$I_1 = I_2 + i_1 + i_2$$

At node 2,

$$I_2 + i_2 = i_3$$

$$i_1 = \frac{v_1 - 0}{R_1}$$

$$i_2 = \frac{v_1 - v_2}{R_2}$$

$$i_3 = \frac{v_2 - 0}{R_3}$$

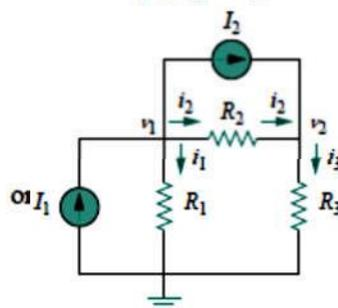

$$I_1 = I_2 + \frac{v_1}{R_1} + \frac{v_1 - v_2}{R_2}$$

$$I_2 + \frac{v_1 - v_2}{R_2} = \frac{v_2}{R_3}$$

Example

Calculate the node voltages in the circuit shown in Fig.

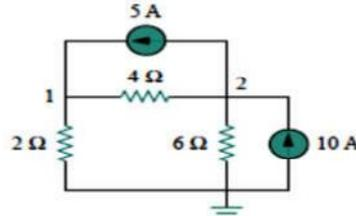

$$i_1 = i_2 + i_3 \implies 5 = \frac{v_1 - v_2}{4} + \frac{v_1 - 0}{2}$$

Multiplying each term in the last equation by 4, we obtain

$$20 = v_1 - v_2 + 2v_1$$

or

$$3v_1 - v_2 = 20$$

At node 2, we do the same thing and get

$$i_2 + i_4 = i_1 + i_5 \implies \frac{v_1 - v_2}{4} + 10 = 5 + \frac{v_2}{6}$$

Multiplying each term by 12 results in

$$3v_1 - 3v_2 + 120 = 60 + 2v_2$$

$$3v_1 + 5v_2 = 60$$

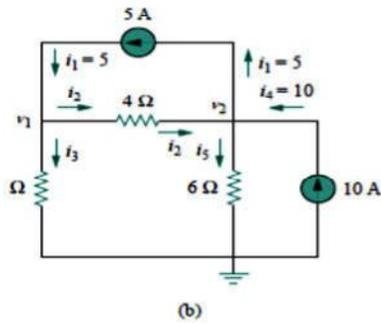

METHOD 1 Using the elimination technique, we add Eqs. (3.1.1) and (3.1.2).

$$4v_2 = 80 \quad \Rightarrow \quad v_2 = 20 \text{ V}$$

Substituting $v_2 = 20$ in Eq. (3.1.1) gives

$$3v_1 - 20 = 20 \quad \Rightarrow \quad v_1 = \frac{40}{3} = 13.33 \text{ V}$$

METHOD 2 To use Cramer's rule, we need to put Eqs. (3.1.1) and (3.1.2) in matrix form as

$$\begin{bmatrix} 3 & -1 \\ -3 & 5 \end{bmatrix} \begin{bmatrix} v_1 \\ v_2 \end{bmatrix} = \begin{bmatrix} 20 \\ 60 \end{bmatrix} \quad (3.1.3)$$

The determinant of the matrix is

$$\Delta = \begin{vmatrix} 3 & -1 \\ -3 & 5 \end{vmatrix} = 15 - 3 = 12$$

We now obtain v_1 and v_2 as

$$v_1 = \frac{\Delta_1}{\Delta} = \frac{\begin{vmatrix} 20 & -1 \\ 60 & 5 \end{vmatrix}}{\Delta} = \frac{100 + 60}{12} = 13.33 \text{ V}$$

$$v_2 = \frac{\Delta_2}{\Delta} = \frac{\begin{vmatrix} 3 & 20 \\ -3 & 60 \end{vmatrix}}{\Delta} = \frac{180 + 60}{12} = 20 \text{ V}$$

giving us the same result as did the elimination method.

If we need the currents, we can easily calculate them from the values of the nodal voltages.

$$i_1 = 5 \text{ A}, \quad i_2 = \frac{v_1 - v_2}{4} = -1.6667 \text{ A}, \quad i_3 = \frac{v_1}{2} = 6.666$$

$$i_4 = 10 \text{ A}, \quad i_5 = \frac{v_2}{6} = 3.333 \text{ A}$$

The fact that i_2 is negative shows that the current flows in the direction opposite to the one assumed.

Practice Problem

Obtain the node voltages in the circuit

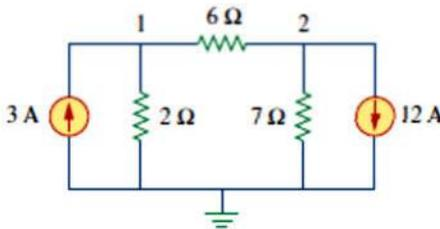

Answer: $v_1 = -6 \text{ V}, v_2 = -42 \text{ V}.$

Example

Determine the voltages at the nodes in Fig (a)

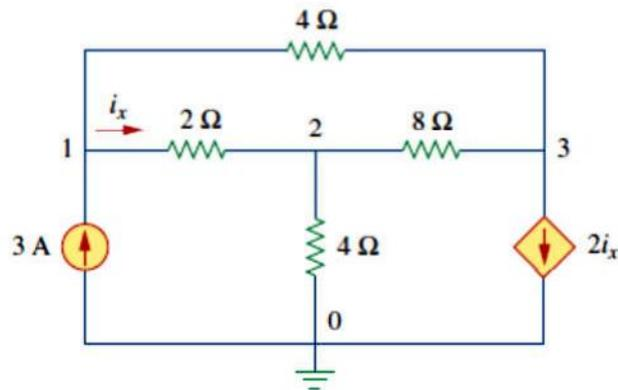

solution

The circuit in this example has three nonreference nodes, unlike the previous example which has two nonreference nodes. We assign voltages to the three nodes as shown in Fig. 3.5(b) and label the currents

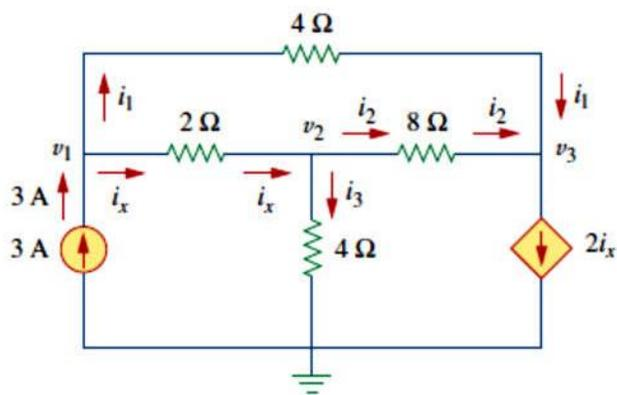

circuit for analysis.

At node 1,

$$3 = i_1 + i_x \Rightarrow 3 = \frac{v_1 - v_3}{4} + \frac{v_1 - v_2}{2}$$

Multiplying by 4 and rearranging terms, we get

$$3v_1 - 2v_2 - v_3 = 12 \quad (3.2.1)$$

At node 2,

$$i_x = i_2 + i_3 \Rightarrow \frac{v_1 - v_2}{2} = \frac{v_2 - v_3}{8} + \frac{v_2 - 0}{4}$$

Multiplying by 8 and rearranging terms, we get

$$-4v_1 + 7v_2 - v_3 = 0 \quad (3.2.2)$$

At node 3,

$$i_1 + i_2 = 2i_x \Rightarrow \frac{v_1 - v_3}{4} + \frac{v_2 - v_3}{8} = \frac{2(v_1 - v_2)}{2}$$

Multiplying by 8, rearranging terms, and dividing by 3, we get

$$2v_1 - 3v_2 + v_3 = 0 \quad (3.2.3)$$

We have three simultaneous equations to solve to get the node voltages v_1 , v_2 , and v_3 . We shall solve the equations in three ways.

■ **METHOD 1** Using the elimination technique, we add Eqs. (3.2.1) and (3.2.3).

$$5v_1 - 5v_2 = 12$$

or

$$v_1 - v_2 = \frac{12}{5} = 2.4 \quad (3.2.4)$$

Adding Eqs. (3.2.2) and (3.2.3) gives

$$-2v_1 + 4v_2 = 0 \Rightarrow v_1 = 2v_2 \quad (3.2.5)$$

Substituting Eq. (3.2.5) into Eq. (3.2.4) yields

$$2v_2 - v_2 = 2.4 \Rightarrow v_2 = 2.4, \quad v_1 = 2v_2 = 4.8 \text{ V}$$

From Eq. (3.2.3), we get

$$v_3 = 3v_2 - 2v_1 = 3v_2 - 4v_2 = -v_2 = -2.4 \text{ V}$$

Thus,

$$v_1 = 4.8 \text{ V}, \quad v_2 = 2.4 \text{ V}, \quad v_3 = -2.4 \text{ V}$$

METHOD 2 To use Cramer's rule, we put Eqs. (3.2.1) to (3.2.3) in matrix form.

$$\begin{bmatrix} 3 & -2 & -1 \\ -4 & 7 & -1 \\ 2 & -3 & 1 \end{bmatrix} \begin{bmatrix} v_1 \\ v_2 \\ v_3 \end{bmatrix} = \begin{bmatrix} 12 \\ 0 \\ 0 \end{bmatrix} \quad (3.2.6)$$

From this, we obtain

$$v_1 = \frac{\Delta_1}{\Delta}, \quad v_2 = \frac{\Delta_2}{\Delta}, \quad v_3 = \frac{\Delta_3}{\Delta}$$

where Δ , Δ_1 , Δ_2 , and Δ_3 are the determinants to be calculated as follows. As explained in Appendix A, to calculate the determinant of a 3 by 3 matrix, we repeat the first two rows and cross multiply.

$$\Delta = \begin{vmatrix} 3 & -2 & -1 \\ -4 & 7 & -1 \\ 2 & -3 & 1 \end{vmatrix} = \begin{vmatrix} 3 & -2 & -1 \\ -4 & 7 & -1 \\ 2 & -3 & 1 \\ 3 & -2 & -1 \\ -4 & 7 & -1 \end{vmatrix} = 21 - 12 + 4 + 14 - 9 - 8 = 10$$

Similarly, we obtain

$$\Delta_1 = \begin{vmatrix} 12 & -2 & -1 \\ 0 & 7 & -1 \\ 0 & -3 & 1 \\ 12 & -2 & -1 \\ 0 & 7 & -1 \end{vmatrix} = 84 + 0 + 0 - 0 - 36 - 0 = 48$$

$$\Delta_2 = \begin{vmatrix} 3 & 12 & -1 \\ -4 & 0 & -1 \\ 2 & 0 & 1 \\ 3 & 12 & -1 \\ -4 & 0 & -1 \end{vmatrix} = 0 + 0 - 24 - 0 - 0 + 48 = 24$$

$$\Delta_3 = \begin{vmatrix} 3 & -2 & 12 \\ -4 & 7 & 0 \\ 2 & -3 & 0 \\ 3 & -2 & 12 \\ -4 & 7 & 0 \end{vmatrix} = 0 + 144 + 0 - 168 - 0 - 0 = -24$$

Thus, we find

$$v_1 = \frac{\Delta_1}{\Delta} = \frac{48}{10} = 4.8 \text{ V}, \quad v_2 = \frac{\Delta_2}{\Delta} = \frac{24}{10} = 2.4 \text{ V}$$

$$v_3 = \frac{\Delta_3}{\Delta} = \frac{-24}{10} = -2.4 \text{ V}$$

as we obtained with Method 1.

Practice Problem

Find the voltages at the three nonreference nodes in the circuit

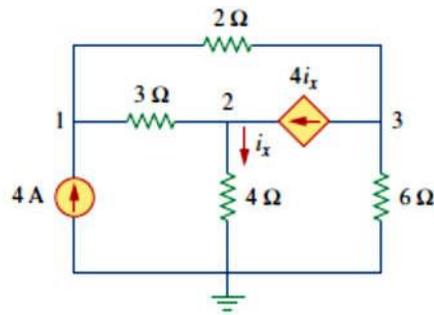

NODAL ANALYSIS WITH VOLTAGE SOURCES

We now consider how voltage sources affect nodal analysis. We use the circuit in Fig. 3.7 for illustration. Consider the following two possibilities.

CASE If a voltage source is connected between the reference node and a nonreference node, we simply set the voltage at the nonreference node equal to the voltage of the voltage source. In Fig. 5, for example

$$v_1 = 10 \text{ V}$$

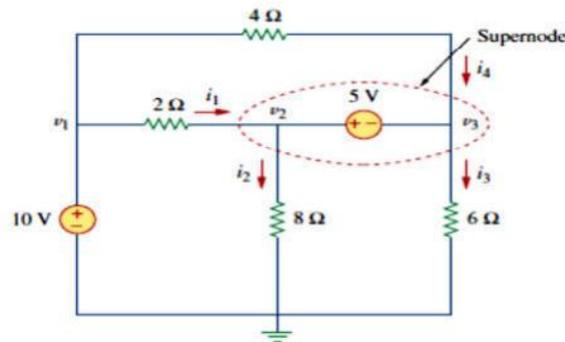
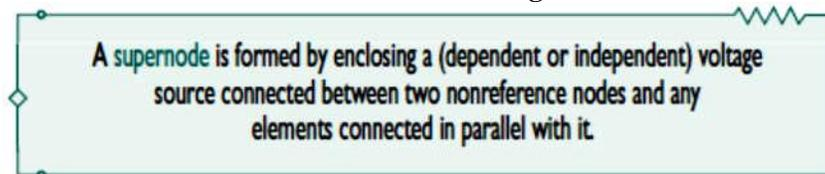

Fig. 5

CASE If the voltage source (dependent or independent) is connected between two nonreference nodes, the two nonreference nodes form *supernode*; we apply both KCL and KVL to determine the node voltages.



$$i_1 + i_4 = i_2 + i_3 \quad (3.11a)$$

or

$$\frac{v_1 - v_2}{2} + \frac{v_1 - v_3}{4} = \frac{v_2 - 0}{8} + \frac{v_3 - 0}{6} \quad (3.11b)$$

To apply Kirchhoff's voltage law to the supernode in Fig. 5, we redraw the circuit as shown in Fig. 6. Going around the loop in the clockwise direction gives

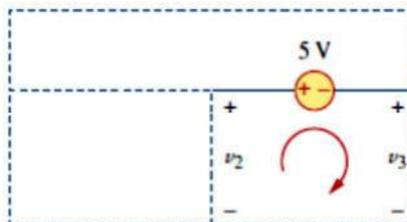

$$-v_2 + 5 + v_3 = 0 \quad \Rightarrow \quad v_2 - v_3 = 5$$

Note the following properties of a supernode:

1. The voltage source inside the supernode provides a constraint equation needed to solve for the node voltages.
2. A supernode has no voltage of its own.
3. A supernode requires the application of both KCL and KVL.

Example

For the circuit shown in Fig. find the node voltages.

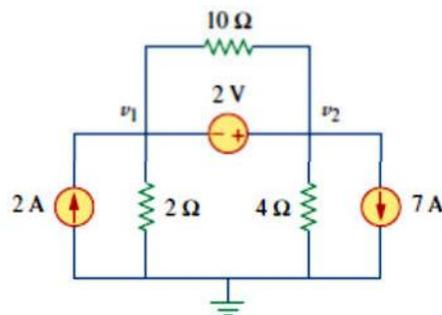

Solution:

The supernode contains the 2-V source, nodes 1 and 2, and the 10Ω resistor. Applying KCL to the supernode as shown in Fig. 5. (a) gives

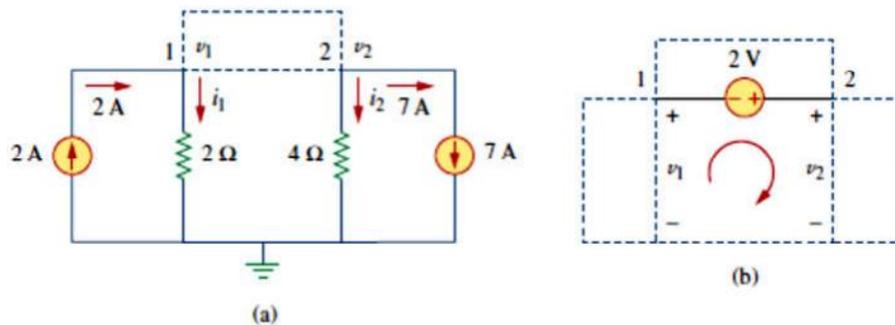

Fig 5

$$2 = i_1 + i_2 + 7$$

Expressing i_1 and i_2 in terms of the node voltages

$$2 = \frac{v_1 - 0}{2} + \frac{v_2 - 0}{4} + 7 \quad \Rightarrow \quad 8 = 2v_1 + v_2 + 28$$

or

$$v_2 = -20 - 2v_1 \quad (3.3.1)$$

To get the relationship between V_1 and V_2 we apply KVL to the circuit in Fig. 5. (b).
 Going around the loop, we obtain

$$-v_1 - 2 + v_2 = 0 \Rightarrow v_2 = v_1 + 2 \quad (3.3.2)$$

From Eqs. (3.3.1) and (3.3.2), we write

$$v_2 = v_1 + 2 = -20 - 2v_1$$

or

$$3v_1 = -22 \Rightarrow v_1 = -7.333 \text{ V}$$

and $v_2 = v_1 + 2 = -5.333 \text{ V}$. Note that the $10\text{-}\Omega$ resistor does not make any difference because it is connected across the supernode.

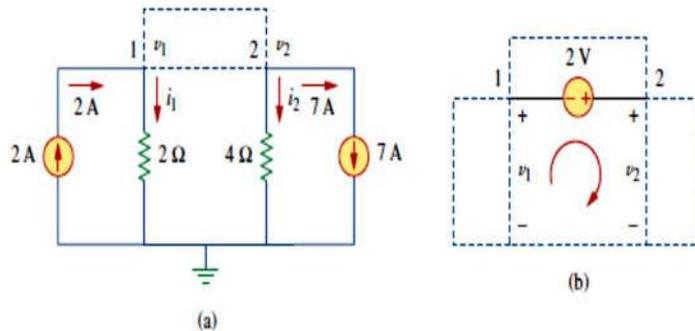

Applying: (a) KCL to the supernode, (b) KVL to the loop.

Practice Problem

Find v and i in the circuit of Fig.

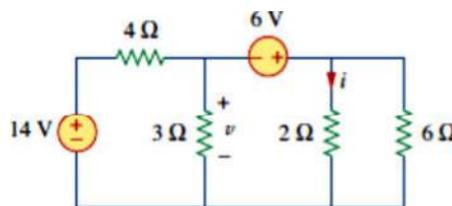

Answer: $-400 \text{ mV}, 2.8 \text{ A}$.

Example

Find the node voltages in the circuit of Fig

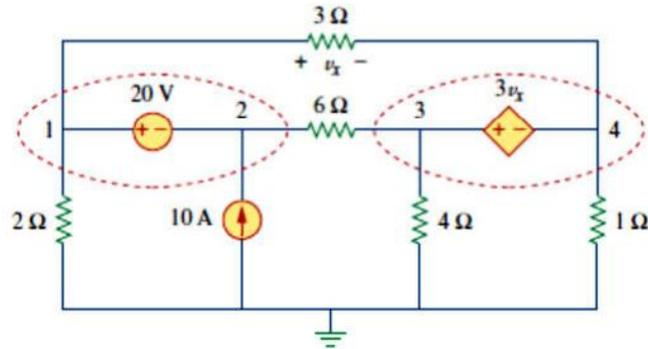

Solution:

Nodes 1 and 2 form a supernode; so do nodes 3 and 4. We apply KCL to the two supernodes as in Fig. 6 . (a). At supernode 1-2,

$$i_3 + 10 = i_1 + i_2$$

Expressing this in terms of the node voltages,

$$\frac{v_3 - v_2}{6} + 10 = \frac{v_1 - v_4}{3} + \frac{v_1}{2}$$

or

$$5v_1 + v_2 - v_3 - 2v_4 = 60 \quad (3.4.1)$$

At supernode 3-4,

$$i_1 = i_3 + i_4 + i_5 \Rightarrow \frac{v_1 - v_4}{3} = \frac{v_3 - v_2}{6} + \frac{v_4}{1} + \frac{v_3}{4}$$

or

$$4v_1 + 2v_2 - 5v_3 - 16v_4 = 0 \quad (3.4.2)$$

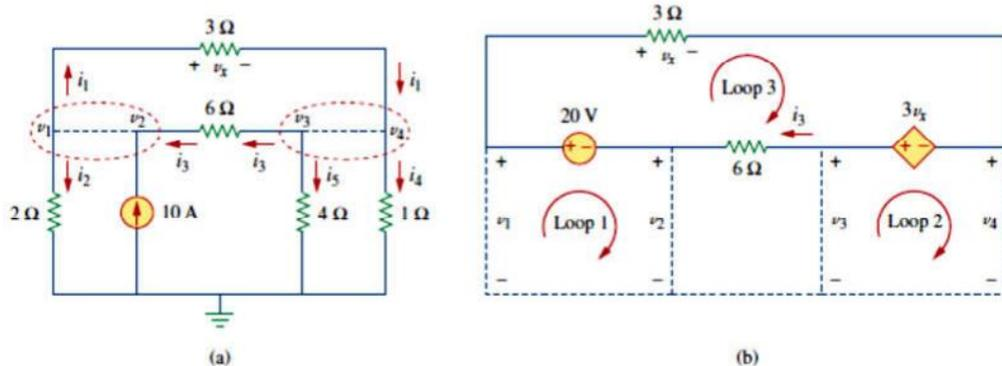

Fig 6

We now apply KVL to the branches involving the voltage sources as shown in Fig. 6. (b). For loop 1,

$$-v_1 + 20 + v_2 = 0 \quad \Rightarrow \quad v_1 - v_2 = 20 \quad (3.4.3)$$

For loop 2,

$$-v_3 + 3v_x + v_4 = 0$$

But $v_x = v_1 - v_4$ so that

$$3v_1 - v_3 - 2v_4 = 0 \quad (3.4.4)$$

For loop 3,

$$v_x - 3v_x + 6i_3 - 20 = 0$$

But $6i_3 = v_3 - v_2$ and $v_x = v_1 - v_4$. Hence,

$$-2v_1 - v_2 + v_3 + 2v_4 = 20 \quad (3.4.5)$$

We need four node voltages, v_1 , v_2 , v_3 , and v_4 , and it requires only four out of the five Eqs. (3.4.1) to (3.4.5) to find them. Although the fifth equation is redundant, it can be used to check results. We can solve Eqs. (3.4.1) to (3.4.4) directly using *MATLAB*. We can eliminate one node voltage so that we solve three simultaneous equations instead of four. From Eq. (3.4.3), $v_2 = v_1 - 20$. Substituting this into Eqs. (3.4.1) and (3.4.2), respectively, gives

$$6v_1 - v_3 - 2v_4 = 80 \quad (3.4.6)$$

and

$$6v_1 - 5v_3 - 16v_4 = 40 \quad (3.4.7)$$

Equations (3.4.4), (3.4.6), and (3.4.7) can be cast in matrix form as

$$\begin{bmatrix} 3 & -1 & -2 \\ 6 & -1 & -2 \\ 6 & -5 & -16 \end{bmatrix} \begin{bmatrix} v_1 \\ v_3 \\ v_4 \end{bmatrix} = \begin{bmatrix} 0 \\ 80 \\ 40 \end{bmatrix}$$

Using Cramer's rule gives

$$\Delta = \begin{vmatrix} 3 & -1 & -2 \\ 6 & -1 & -2 \\ 6 & -5 & -16 \end{vmatrix} = -18, \quad \Delta_1 = \begin{vmatrix} 0 & -1 & -2 \\ 80 & -1 & -2 \\ 40 & -5 & -16 \end{vmatrix} = -480,$$

$$\Delta_3 = \begin{vmatrix} 3 & 0 & -2 \\ 6 & 80 & -2 \\ 6 & 40 & -16 \end{vmatrix} = -3120, \quad \Delta_4 = \begin{vmatrix} 3 & -1 & 0 \\ 6 & -1 & 80 \\ 6 & -5 & 40 \end{vmatrix} = 840$$

Thus, we arrive at the node voltages as

$$v_1 = \frac{\Delta_1}{\Delta} = \frac{-480}{-18} = 26.67 \text{ V}, \quad v_3 = \frac{\Delta_3}{\Delta} = \frac{-3120}{-18} = 173.33 \text{ V},$$

$$v_4 = \frac{\Delta_4}{\Delta} = \frac{840}{-18} = -46.67 \text{ V}$$

and $v_2 = v_1 - 20 = 6.667 \text{ V}$. We have not used Eq. (3.4.5); it can be used to cross check results.

Practice Problem

Find v_1 , v_2 , and v_3 , in the circuit of Fig. using nodal analysis

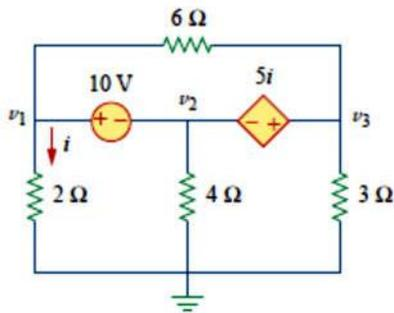

Mesh Analysis

Nodal analysis applies KCL to find unknown voltages in a given circuit, while mesh analysis applies KVL to find unknown currents

A mesh is a loop which does not contain any other loops within it.

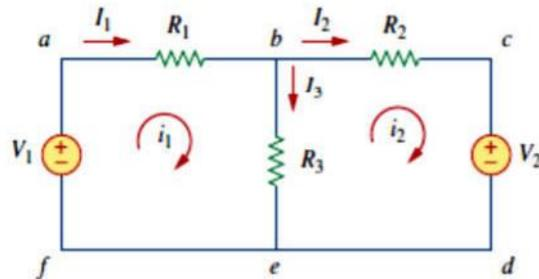

In Fig for example, paths $abefa$ and $bcdeb$ are meshes, but path $abcdefa$ is not a mesh. The current through a mesh is known as *mesh current*. In mesh analysis, we are interested in applying KVL to find the mesh currents in a given circuit.

Steps to Determine Mesh Currents:

1. Assign mesh currents i_1, i_2, \dots, i_n to the n meshes.
2. Apply KVL to each of the n meshes. Use Ohm's law to express the voltages in terms of the mesh currents.
3. Solve the resulting n simultaneous equations to get the mesh currents.

To illustrate the steps, consider the circuit in Fig. above. The first step requires that mesh currents i_1 and i_2 are assigned to meshes 1 and 2. Although a mesh current may be assigned to each mesh in an arbitrary direction, it is conventional to assume that each mesh current flows clockwise.

As the second step, we apply KVL to each mesh. Applying KVL to mesh 1, we obtain

$$-V_1 + R_1 i_1 + R_3(i_1 - i_2) = 0$$

or

$$(R_1 + R_3)i_1 - R_3 i_2 = V_1 \quad (3.13)$$

For mesh 2, applying KVL gives

$$R_2 i_2 + V_2 + R_3(i_2 - i_1) = 0$$

or

$$-R_3 i_1 + (R_2 + R_3)i_2 = -V_2 \quad (3.14)$$

$$I_1 = i_1, \quad I_2 = i_2, \quad I_3 = i_1 - i_2$$

Example

For the circuit in Fig. find the branch currents and using mesh analysis

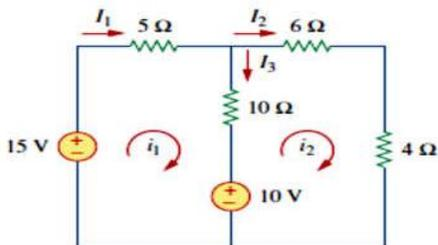

Solution:

We first obtain the mesh currents using KVL. For mesh 1,

$$-15 + 5i_1 + 10(i_1 - i_2) + 10 = 0$$

or

$$3i_1 - 2i_2 = 1 \quad (3.5.1)$$

For mesh 2,

$$6i_2 + 4i_2 + 10(i_2 - i_1) - 10 = 0$$

or

$$i_1 = 2i_2 - 1 \quad (3.5.2)$$

■ **METHOD 1** Using the substitution method, we substitute Eq. (3.5.2) into Eq. (3.5.1), and write

$$6i_2 - 3 - 2i_2 = 1 \quad \Rightarrow \quad i_2 = 1 \text{ A}$$

From Eq. (3.5.2), $i_1 = 2i_2 - 1 = 2 - 1 = 1 \text{ A}$. Thus,

$$I_1 = i_1 = 1 \text{ A}, \quad I_2 = i_2 = 1 \text{ A}, \quad I_3 = i_1 - i_2 = 0$$

■ **METHOD 2** To use Cramer's rule, we cast Eqs. (3.5.1) and (3.5.2) in matrix form as

$$\begin{bmatrix} 3 & -2 \\ -1 & 2 \end{bmatrix} \begin{bmatrix} i_1 \\ i_2 \end{bmatrix} = \begin{bmatrix} 1 \\ 1 \end{bmatrix}$$

We obtain the determinants

$$\Delta = \begin{vmatrix} 3 & -2 \\ -1 & 2 \end{vmatrix} = 6 - 2 = 4$$

$$\Delta_1 = \begin{vmatrix} 1 & -2 \\ 1 & 2 \end{vmatrix} = 2 + 2 = 4, \quad \Delta_2 = \begin{vmatrix} 3 & 1 \\ -1 & 1 \end{vmatrix} = 3 + 1 = 4$$

Thus,

$$i_1 = \frac{\Delta_1}{\Delta} = 1 \text{ A}, \quad i_2 = \frac{\Delta_2}{\Delta} = 1 \text{ A}$$

as before.

[Practice Problem](#)

Calculate the mesh currents i_1 and i_2 of the circuit of Fig

Answer: $i_1 = 2.5 \text{ A}$, $i_2 = 0 \text{ A}$.

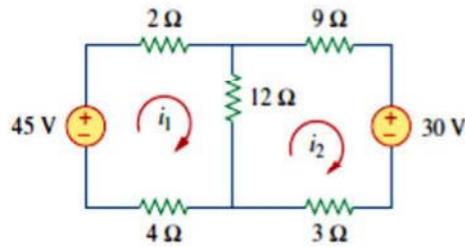

Example

Use mesh analysis to find the current i_o in the circuit of Fig.

Solution:

We apply KVL to the three meshes in turn. For mesh 1,

$$-24 + 10(i_1 - i_2) + 12(i_1 - i_3) = 0$$

or

$$11i_1 - 5i_2 - 6i_3 = 12 \quad (3.6.1)$$

For mesh 2,

$$24i_2 + 4(i_2 - i_3) + 10(i_2 - i_1) = 0$$

or

$$-5i_1 + 19i_2 - 2i_3 = 0 \quad (3.6.2)$$

For mesh 3,

$$4I_o + 12(i_3 - i_1) + 4(i_3 - i_2) = 0$$

But at node A, $I_o = i_1 - i_2$, so that

$$4(i_1 - i_2) + 12(i_3 - i_1) + 4(i_3 - i_2) = 0$$

or

$$-i_1 - i_2 + 2i_3 = 0 \quad (3.6.3)$$

In matrix form, Eqs. (3.6.1) to (3.6.3) become

$$\begin{bmatrix} 11 & -5 & -6 \\ -5 & 19 & -2 \\ -1 & -1 & 2 \end{bmatrix} \begin{bmatrix} i_1 \\ i_2 \\ i_3 \end{bmatrix} = \begin{bmatrix} 12 \\ 0 \\ 0 \end{bmatrix}$$

We obtain the determinants as

$$\Delta = \begin{vmatrix} 11 & -5 & -6 \\ -5 & 19 & -2 \\ -1 & -1 & 2 \end{vmatrix} = 418 - 30 - 10 - 114 - 22 - 50 = 192$$

$$\Delta_1 = \begin{vmatrix} 12 & -5 & -6 \\ 0 & 19 & -2 \\ 0 & -1 & 2 \end{vmatrix} = 456 - 24 = 432$$

$$\Delta_2 = \begin{vmatrix} 11 & 12 & -6 \\ -5 & 0 & -2 \\ -1 & 0 & 2 \end{vmatrix} = 24 + 120 = 144$$

$$\Delta_3 = \begin{vmatrix} 11 & -5 & 12 \\ -5 & 19 & 0 \\ -1 & -1 & 0 \end{vmatrix} = 60 + 228 = 288$$

We calculate the mesh currents using Cramer's rule as

$$i_1 = \frac{\Delta_1}{\Delta} = \frac{432}{192} = 2.25 \text{ A}, \quad i_2 = \frac{\Delta_2}{\Delta} = \frac{144}{192} = 0.75 \text{ A},$$

$$i_3 = \frac{\Delta_3}{\Delta} = \frac{288}{192} = 1.5 \text{ A}$$

Thus, $I_o = i_1 - i_2 = 1.5 \text{ A}$.

Practice Problem

Using mesh analysis, find I_o in the circuit of Fig.

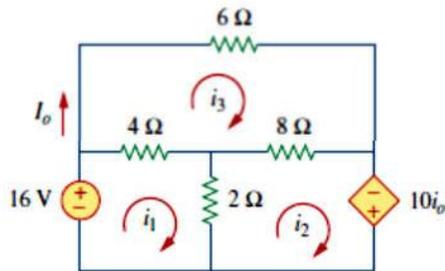

Answer: - 4 A.

Mesh Analysis with Current Sources

Applying mesh analysis to circuits containing current sources (dependent or independent) Consider the following two possible cases Applying mesh analysis to circuits containing current sources (dependent or independent) may appear complicated. But it is actually much easier than what we encountered in the previous section, because the presence of the current sources reduces the number of equations. Consider the following two possible cases.

🕒 **CASE 1** When a current source exists only in one mesh: Consider the circuit for example. We set $i_2 = -5\text{ A}$ and write a mesh equation for the other mesh in the usual way; that is,

$$-10 + 4i_1 + 6(i_1 - i_2) = 0 \quad \Rightarrow \quad i_1 = -2\text{ A} \quad (3.17)$$

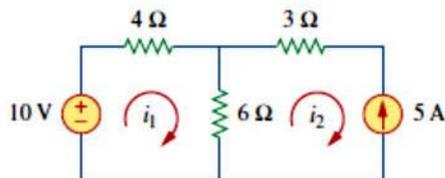

🕒 **CASE 2** When a current source exists between two meshes: Consider the circuit in Fig. 7. (a), for example. We create a *supermesh* by excluding the current source and any elements connected in series with it, as shown in Fig. 7. (b). Thus,

A **supermesh** results when two meshes have a (dependent or independent) current source in common.

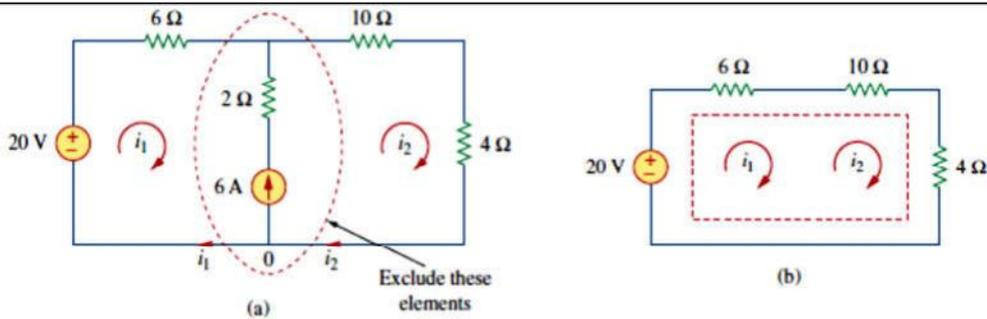

Fig 7

(a) Two meshes having a current source in common, (b) a supermesh, created by excluding the current source

As shown in Fig.7 (b), we create a supermesh as the periphery of the two meshes and treat it differently. (If a circuit has two or more supermeshes that intersect, they should be combined to form a larger supermesh.) Why treat the supermesh differently? Because mesh analysis applies KVL—which requires that we know the voltage across each branch—and we do not know the voltage across a current source in advance. However, a supermesh must satisfy KVL like any other mesh. Therefore, applying KVL to the supermesh in Fig. (b) gives

$$-20 + 6i_1 + 10i_2 + 4i_2 = 0$$

or

$$6i_1 + 14i_2 = 20 \quad (3.18)$$

We apply KCL to a node in the branch where the two meshes intersect. Applying KCL to node 0 in Fig (a) gives

$$i_2 = i_1 + 6 \quad (3.19)$$

Solving Eqs. (3.18) and (3.19), we get

$$i_1 = -3.2 \text{ A}, \quad i_2 = 2.8 \text{ A} \quad (3.20)$$

Note the following properties of a supermesh:

1. The current source in the supermesh provides the constraint equation necessary to solve for the mesh currents.
2. A supermesh has no current of its own.
3. A supermesh requires the application of both KVL and KCL.

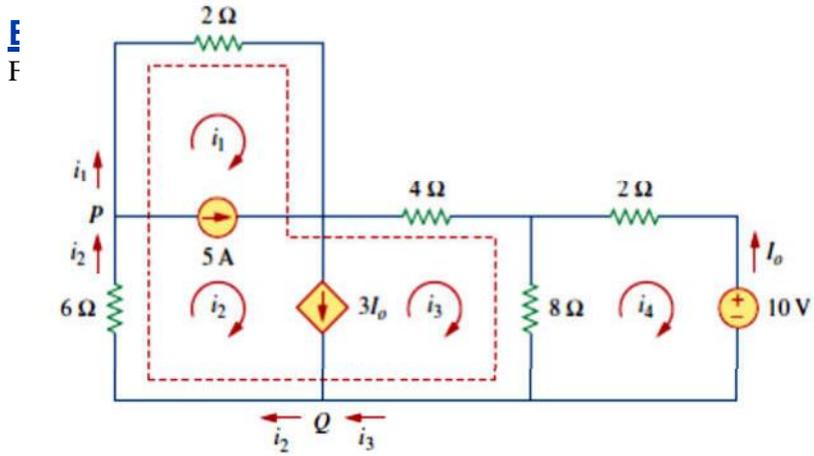

Solution:

Note that meshes 1 and 2 form a supermesh since they have an independent current source in common. Also, meshes 2 and 3 form another supermesh because they have a dependent current source in common. The two supermeshes intersect and form a larger supermesh as shown. Applying KVL to the larger supermesh

$$2i_1 + 4i_3 + 8(i_3 - i_4) + 6i_2 = 0$$

or

$$i_1 + 3i_2 + 6i_3 - 4i_4 = 0 \quad (3.7.1)$$

For the independent current source, we apply KCL to node P :

$$i_2 = i_1 + 5 \quad (3.7.2)$$

For the dependent current source, we apply KCL to node Q :

$$i_2 = i_3 + 3I_o$$

But $I_o = -i_4$, hence,

$$i_2 = i_3 - 3i_4 \quad (3.7.3)$$

Applying KVL in mesh 4,

$$2i_4 + 8(i_4 - i_3) + 10 = 0$$

or

$$5i_4 - 4i_3 = -5 \quad (3.7.4)$$

From Eqs. (3.7.1) to (3.7.4),

$$i_1 = -7.5 \text{ A}, \quad i_2 = -2.5 \text{ A}, \quad i_3 = 3.93 \text{ A}, \quad i_4 = 2.143 \text{ A}$$

Practice Problem

Use mesh analysis to determine i_1 , i_2 and i_3 in

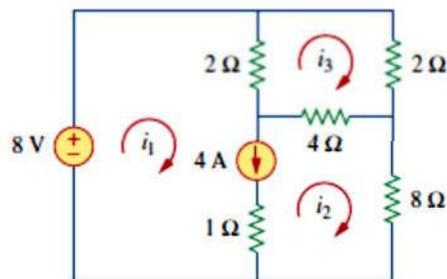

Answer: $i_1 = 4.632 \text{ A}$, $i_2 = 631.6 \text{ mA}$, $i_3 = 1.4736 \text{ A}$.

Summary

1. Nodal analysis is the application of Kirchhoff's current law at the nonreference nodes. (It is applicable to both planar and nonplanar circuits.) We express the result in terms of the node voltages. Solving the simultaneous equations yields the node voltages.
2. A supernode consists of two nonreference nodes connected by a (dependent or independent) voltage source.
3. Mesh analysis is the application of Kirchhoff's voltage law around meshes in a planar circuit. We express the result in terms of mesh currents. Solving the simultaneous equations yields the mesh currents.
4. A supermesh consists of two meshes that have a (dependent or independent) current source in common.
5. Nodal analysis is normally used when a circuit has fewer node equations than mesh equations. Mesh analysis is normally used when a circuit has fewer mesh equations than node equations.
6. Circuit analysis can be carried out using *PSpice*.
7. DC transistor circuits can be analyzed using the techniques covered in this chapter.

*Fundamentals of
Electric Circuits*

First Semester

CHAPTER FOUR

CIRCUIT THEOREMS

CIRCUIT THEOREMS

LINEARITY PROPERTY

Linearity is the property of an element describing a linear relationship between cause and effect. Although the property applies to many circuit elements, we shall limit its applicability to resistors in this chapter. The property is a combination of both the homogeneity (scaling) property and the additivity property. The homogeneity property requires that if the input (also called the *excitation*) is multiplied by a constant, then the output (also called the *response*) is multiplied by the same constant. For a resistor, for example, Ohm's law relates the input i to the output v ,

$$v = iR \quad (4.1)$$

If the current is increased by a constant k , then the voltage increases correspondingly by k ; that is,

$$kiR = kv \quad (4.2)$$

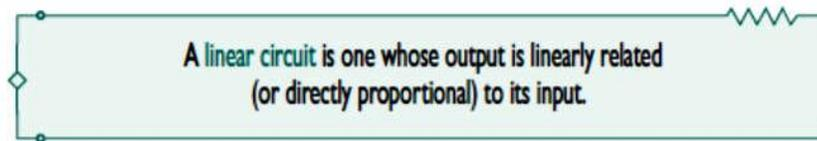

To understand the linearity principle, consider the linear circuit shown in Fig. 4.1. The linear circuit has no independent sources inside it. It is excited by a voltage source v_s , which serves as the input. The circuit is terminated by a load R . We may take the current i through R as the output. Suppose $v_s = 10$ V gives $i = 2$ A. According to the linearity principle, $v_s = 1$ V will give $i = 0.2$ A. By the same token, $i = 1$ mA must be due to $v_s = 5$ mV

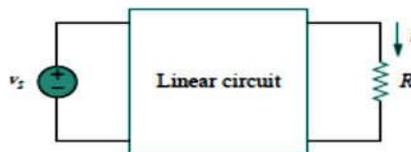

Figure 4.1 A linear circuit with input v_s and output i .

Example

For the circuit find I_o when $V_s = 12\text{ V}$ and $V_s = 24\text{ V}$

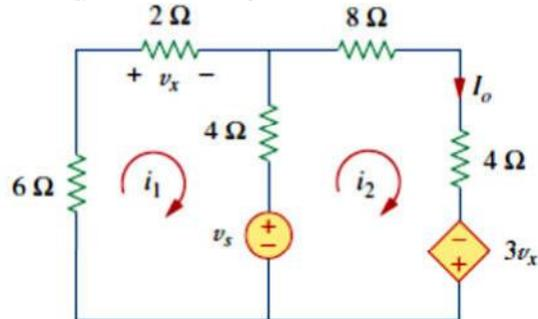

Figure 4.2

Solution:

Applying KVL to the two loops, we obtain

$$12i_1 - 4i_2 + v_s = 0 \quad (4.1.1)$$

$$-4i_1 + 16i_2 - 3v_x - v_s = 0 \quad (4.1.2)$$

But $v_x = 2i_1$. Equation (4.1.2) becomes

$$-10i_1 + 16i_2 - v_s = 0 \quad (4.1.3)$$

Adding Eqs. (4.1.1) and (4.1.3) yields

$$2i_1 + 12i_2 = 0 \quad \Rightarrow \quad i_1 = -6i_2$$

Substituting this in Eq. (4.1.1), we get

$$-76i_2 + v_s = 0 \quad \Rightarrow \quad i_2 = \frac{v_s}{76}$$

When $v_s = 12\text{ V}$,

$$I_o = i_2 = \frac{12}{76}\text{ A}$$

When $v_s = 24\text{ V}$,

$$I_o = i_2 = \frac{24}{76}\text{ A}$$

showing that when the source value is doubled, I_o doubles.

Practice Problem

For the circuit find v_o when $i_s = 30$ A and $i_s = 45$ A

Answer: 40 V, 60 V.

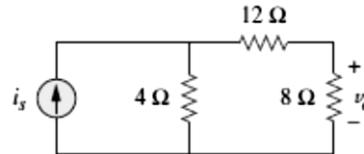

Example

Assume $I_o = 1$ A, and use linearity to find the actual value of I_o in the circuit.

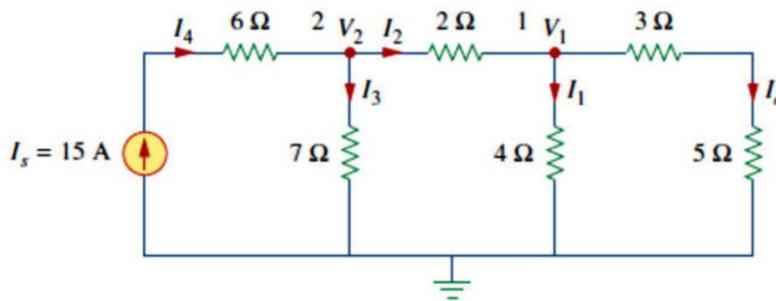

Solution:

If $I_o = 1$ A, then $V_1 = (3 + 5)I_o = 8$ V and $I_1 = V_1/4 = 2$ A. Applying KCL at node 1 gives

$$I_2 = I_1 + I_o = 3 \text{ A}$$

$$V_2 = V_1 + 2I_2 = 8 + 6 = 14 \text{ V}, \quad I_3 = \frac{V_2}{7} = 2 \text{ A}$$

Applying KCL at node 2 gives

$$I_4 = I_3 + I_2 = 5 \text{ A}$$

Therefore, $I_s = 5$ A. This shows that assuming $I_o = 1$ gives $I_s = 5$ A, the actual source current of 15 A will give $I_o = 3$ A as the actual value.

Practice Problem

Assume that $V_o = 1$ V and use linearity to calculate the actual value of V_o in the circuit

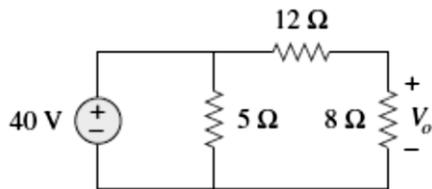

Answer: 16

SUPERPOSITION

The superposition principle states that the voltage across (or current through) an element in a linear circuit is the algebraic sum of the voltages across (or currents through) that element due to each independent source acting alone.

With these in mind, we apply the superposition principle in three steps:

Steps to Apply Superposition Principle:

1. Turn off all independent sources except one source. Find the output (voltage or current) due to that active source using nodal or mesh analysis.
2. Repeat step 1 for each of the other independent sources.
3. Find the total contribution by adding algebraically all the contributions due to the independent sources.

Example

Use the superposition theorem to find v in the circuit

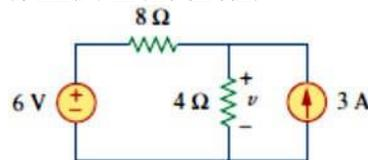

Solution:

Since there are two sources, let

$$v = v_1 + v_2$$

where v_1 and v_2 are the contributions due to the 6-V voltage source and the 3-A current source, respectively. To obtain v_1 , we set the current source to zero, as shown in Fig. (a). Applying KVL to the loop in

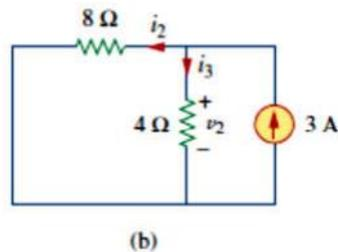
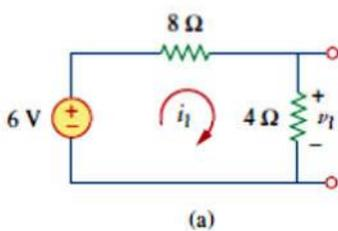

(a) Calculating v_1 (b) calculating v_2 .

$$12i_1 - 6 = 0 \quad \Rightarrow \quad i_1 = 0.5 \text{ A}$$

Thus,

$$v_1 = 4i_1 = 2 \text{ V}$$

We may also use voltage division to get v_1 by writing

$$v_1 = \frac{4}{4 + 8}(6) = 2 \text{ V}$$

To get v_2 , we set the voltage source to zero, as in Fig. 4.7(b). Using current division,

$$i_3 = \frac{8}{4 + 8}(3) = 2 \text{ A}$$

Hence,

$$v_2 = 4i_3 = 8 \text{ V}$$

And we find

$$v = v_1 + v_2 = 2 + 8 = 10 \text{ V}$$

Practice Problem

Using the superposition theorem, find V_o in the circuit of Fig.

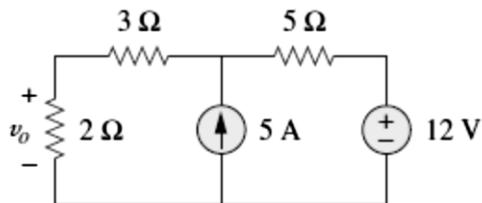

Answer: 7.4 V.

Example

Find i_o in the circuit using superposition theorem.

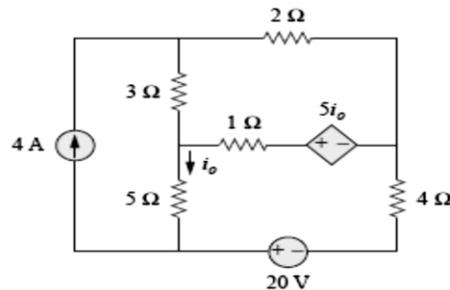

Solution:

The circuit involves a dependent source, which must be left intact. We let

$$i_o = i'_o + i''_o \quad (4.4.1)$$

where i'_o and i''_o are due to the 4-A current source and 20-V voltage source respectively. To obtain i'_o , we turn off the 20-V source so that we have the circuit in Fig. (a). We apply mesh analysis in order to obtain i'_o . For loop 1,

$$i_1 = 4 \text{ A} \quad (4.4.2)$$

For loop 2,

$$-3i_1 + 6i_2 - 1i_3 - 5i'_o = 0 \quad (4.4.3)$$

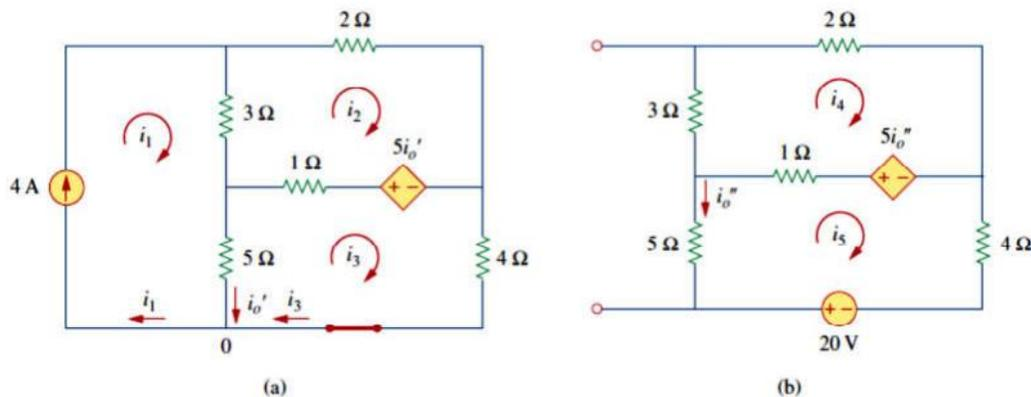

Applying superposition to (a) obtain i'_o , (b) obtain i''_o .

For loop 3,

$$-5i_1 - 1i_2 + 10i_3 + 5i'_o = 0 \quad (4.4.4)$$

But at node 0,

$$i_3 = i_1 - i'_o = 4 - i'_o \quad (4.4.5)$$

Substituting Eqs. (4.4.2) and (4.4.5) into Eqs. (4.4.3) and (4.4.4) gives two simultaneous equations

$$3i_2 - 2i'_o = 8 \quad (4.4.6)$$

$$i_2 + 5i'_o = 20 \quad (4.4.7)$$

which can be solved to get

$$i'_o = \frac{52}{17} \text{ A} \quad (4.4.8)$$

To obtain i''_o , we turn off the 4-A current source so that the circuit becomes that shown in Fig. . (b). For loop 4, KVL gives

$$6i_4 - i_5 - 5i''_o = 0 \quad (4.4.9)$$

and for loop 5,

$$-i_4 + 10i_5 - 20 + 5i''_o = 0 \quad (4.4.10)$$

But $i_5 = -i''_o$. Substituting this in Eqs. (4.4.9) and (4.4.10) gives

$$6i_4 - 4i''_o = 0 \quad (4.4.11)$$

$$i_4 + 5i''_o = -20 \quad (4.4.12)$$

which we solve to get

$$i''_o = -\frac{60}{17} \text{ A} \quad (4.4.13)$$

Now substituting Eqs. (4.4.8) and (4.4.13) into Eq. (4.4.1) gives

$$i_o = -\frac{8}{17} = -0.4706 \text{ A}$$

Practice Problem

Use superposition to find in the circuit

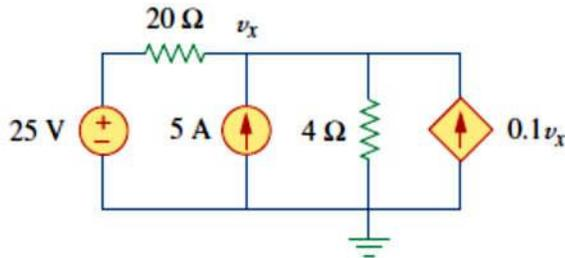

Answer: $v_x = 31.25 \text{ V}$.

Example

For the circuit in Fig. use the superposition theorem to find i .

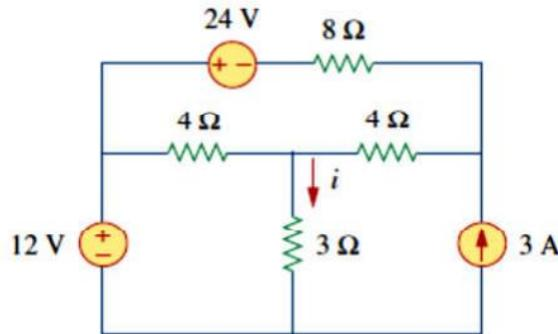

Solution:

In this case, we have three sources. Let

$$i = i_1 + i_2 + i_3$$

where i_1 , i_2 , and i_3 are due to the 12-V, 24-V, and 3-A sources respectively. To get i_1 , consider the circuit in Fig. 4.13(a). Combining 4 Ω (on the right-hand side) in series with 8 Ω gives 12 Ω. The 12 Ω in parallel with 4 Ω gives $12 \times 4/16 = 3 \Omega$. Thus,

$$i_1 = \frac{12}{6} = 2 \text{ A}$$

To get i_2 , consider the circuit in Fig. 4.13(b). Applying mesh analysis gives

$$16i_a - 4i_b + 24 = 0 \quad \Rightarrow \quad 4i_a - i_b = -6 \quad (4.5.1)$$

$$7i_b - 4i_a = 0 \quad \Rightarrow \quad i_a = \frac{7}{4}i_b \quad (4.5.2)$$

Substituting Eq. (4.5.2) into Eq. (4.5.1) gives

$$i_2 = i_b = -1$$

To get i_3 , consider the circuit in Fig. 4.13(c). Using nodal analysis gives

$$3 = \frac{v_2}{8} + \frac{v_2 - v_1}{4} \Rightarrow 24 = 3v_2 - 2v_1 \quad (4.5.3)$$

$$\frac{v_2 - v_1}{4} = \frac{v_1}{4} + \frac{v_1}{3} \Rightarrow v_2 = \frac{10}{3}v_1 \quad (4.5.4)$$

Substituting Eq. (4.5.4) into Eq. (4.5.3) leads to $v_1 = 3$ and

$$i_3 = \frac{v_1}{3} = 1 \text{ A}$$

Thus,

$$i = i_1 + i_2 + i_3 = 2 - 1 + 1 = 2 \text{ A}$$

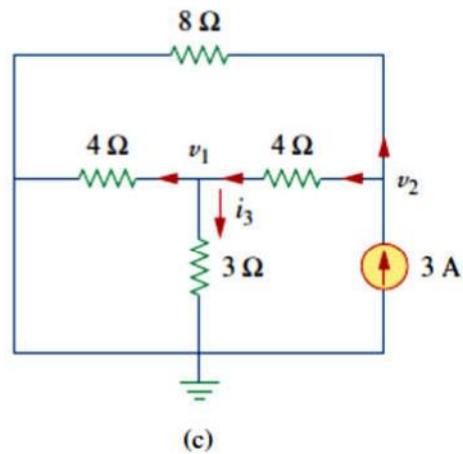
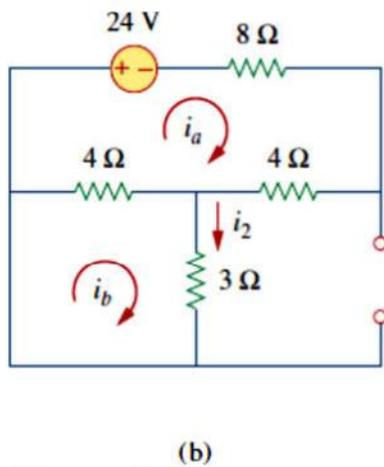
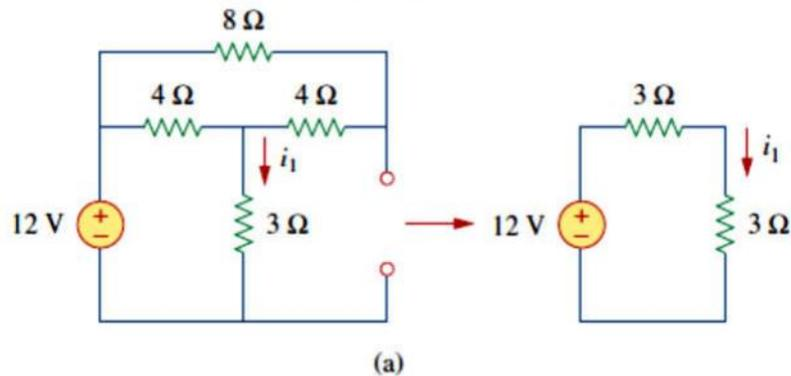
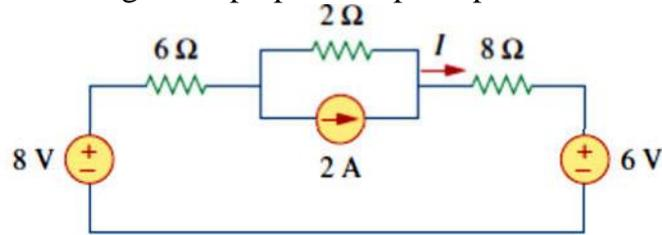

Figure 4.13

Practice Problem

Find I in the circuit using the superposition principle



Answer: 375 mA.

Example

Use superposition to find v_o in the circuit of Fig.

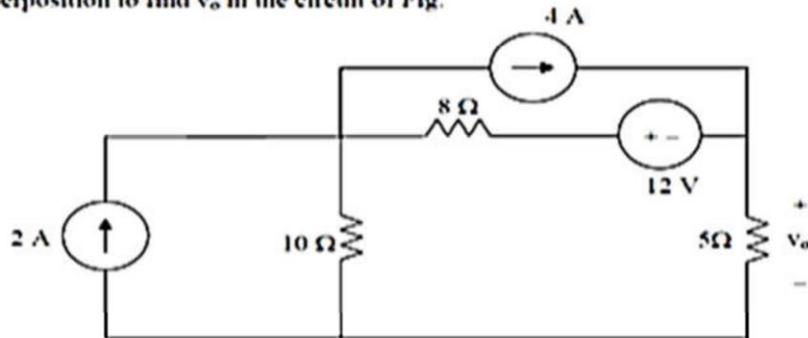

Let $v_o = v_1 + v_2 + v_3$, where v_1 , v_2 , and v_3 are due to the independent sources. To find v_1 , consider the circuit below.

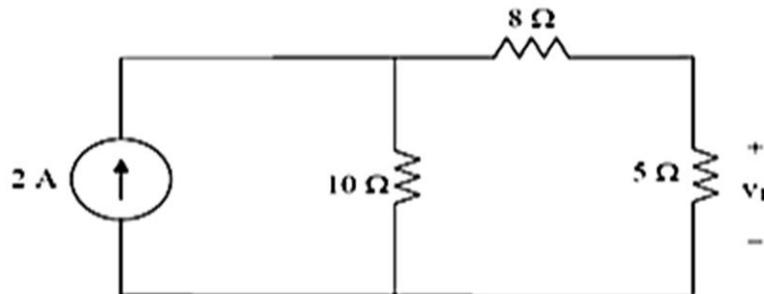

$$v_1 = 5 \times \frac{10}{10+8+5} \times 2 = 4.3478$$

To find v_2 , consider the circuit below.

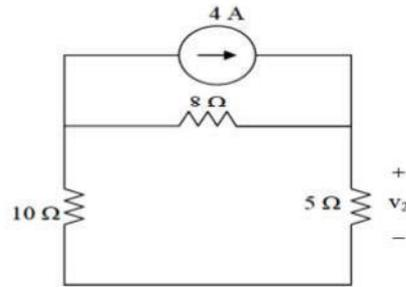

$$v_2 = 5 \times \frac{8}{8+10+5} \times 4 = 6.9565$$

To find v_3 , consider the circuit below.

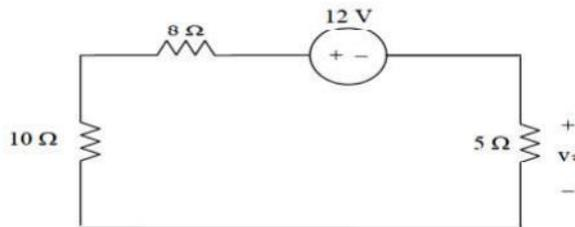

$$v_3 = -12 \left(\frac{5}{5+10+8} \right) = -2.6087$$

$$v_o = v_1 + v_2 + v_3 = 8.6956 \text{ V} = \underline{\underline{8.696 \text{ V}}}$$

Example

Apply the superposition principle to find in the circuit

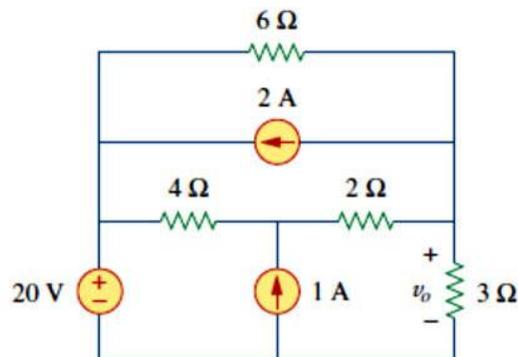

Let $v_o = v_{o1} + v_{o2} + v_{o3}$, where v_{o1} , v_{o2} , and v_{o3} are due to the 20-V, 1-A, and 2-A sources respectively. For v_{o1} , consider the circuit below.

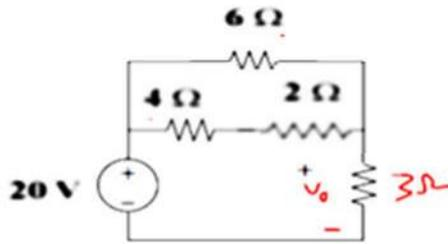

$$6 \parallel (4 + 2) = 3 \text{ ohms}, v_{o1} = \left(\frac{1}{3}\right)20 = 10 \text{ V}$$

For v_{o2} , consider the circuit below.

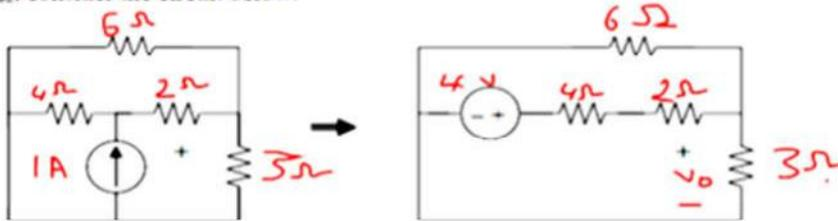

$$3 \parallel 6 = 2 \text{ ohms}, v_{o2} = [2 / (4 + 2 + 2)]4 = 1 \text{ V}$$

For v_{o3} , consider the circuit below.

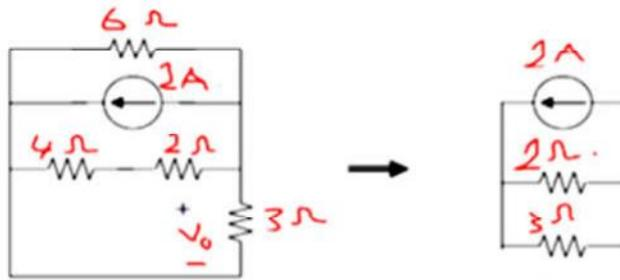

$$6 \parallel (4 + 2) = 3, v_{o3} = (-1)3 = -3$$

$$v_o = 10 + 1 - 3 = \underline{\underline{8 \text{ V}}}$$

Example

For the circuit find the terminal voltage V_{ab} using superposition.

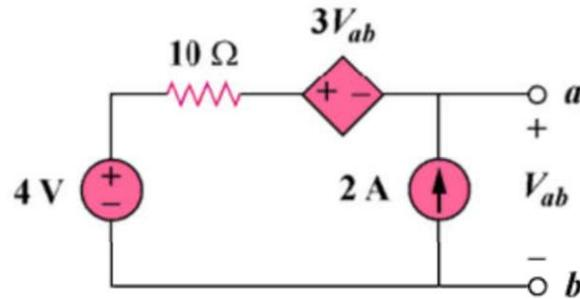

Solution

Let $v_{ab} = v_{ab1} + v_{ab2}$ where v_{ab1} and v_{ab2} are due to the 4-V and the 2-A sources respectively.

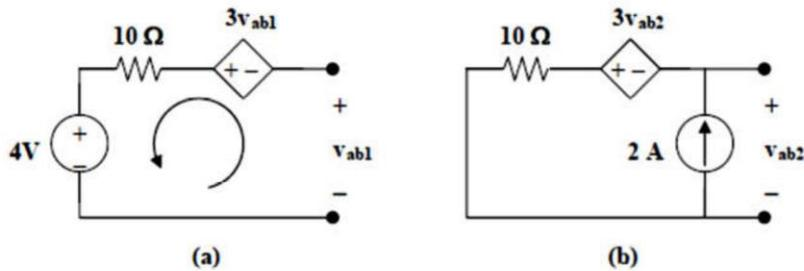

For v_{ab1} , consider Fig. (a). Applying KVL gives,

$$-v_{ab1} - 3v_{ab1} + 10 \times 0 + 4 = 0, \text{ which leads to } v_{ab1} = 1 \text{ V}$$

For v_{ab2} , consider Fig. (b). Applying KVL gives,

$$-v_{ab2} - 3v_{ab2} + 10 \times 2 = 0, \text{ which leads to } v_{ab2} = 5$$

$$v_{ab} = 1 + 5 = 6 \text{ V}$$

Example

Use the superposition principle to find and in the circuit

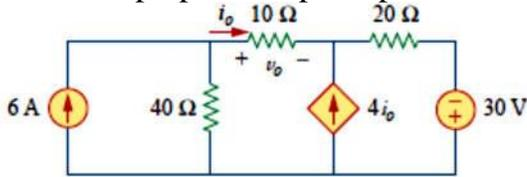

Let $v_o = v_1 + v_2$, where v_1 and v_2 are due to the 6-A and 30-V sources respectively. To find v_1 , consider the circuit below.

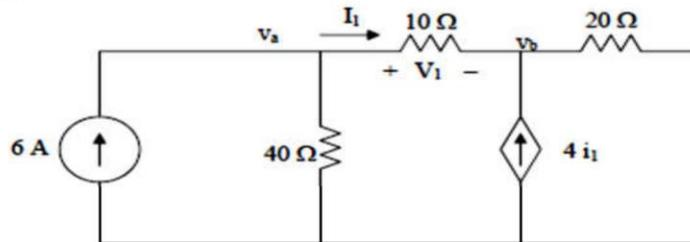

At node a,

$$6 = \frac{v_a}{40} + \frac{v_a - v_b}{10} \longrightarrow 240 = 5v_a - 4v_b \quad (1)$$

At node b,

$$-I_1 - 4I_1 + (v_b - 0)/20 = 0 \text{ or } v_b = 100I_1$$

$$\text{But } i_1 = \frac{v_a - v_b}{10} \text{ which leads to } 100(v_a - v_b)/10 = v_b \text{ or } v_b = 0.9091v_a \quad (2)$$

Substituting (2) into (1),

$$5v_a - 3.636v_a = 240 \text{ or } v_a = 175.95 \text{ and } v_b = 159.96$$

However, $v_1 = v_a - v_b = 15.99 \text{ V}$.

To find v_2 , consider the circuit below.

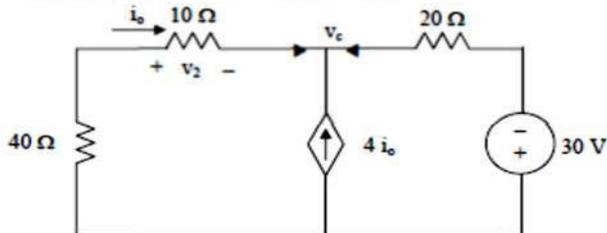

$$\frac{0 - v_c}{50} + 4i_o + \frac{(-30 - v_c)}{20} = 0$$

But $i_o = \frac{(0 - v_c)}{50}$

$$\frac{5v_c}{50} - \frac{(30 + v_c)}{20} = 0 \longrightarrow v_c = -10 \text{ V}$$

$$i_2 = \frac{0 - v_c}{50} = \frac{0 + 10}{50} = \frac{1}{5}$$

$$v_2 = 10i_2 = 2 \text{ V}$$

$$v_o = v_1 + v_2 = 15.99 + 2 = \underline{17.99 \text{ V}} \text{ and } i_o = v_o/10 = \underline{1.799 \text{ A}}$$

Example

Use superposition to find V_o in the circuit of Fig. 4.86.

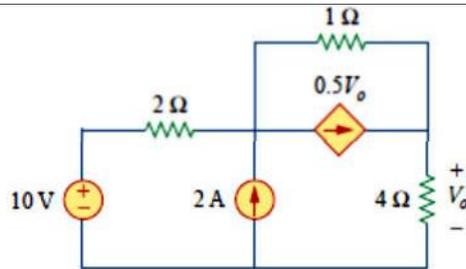

Let $V_o = V_1 + V_2$, where V_1 and V_2 are due to 10-V and 2-A sources respectively. To find V_1 , we use the circuit below.

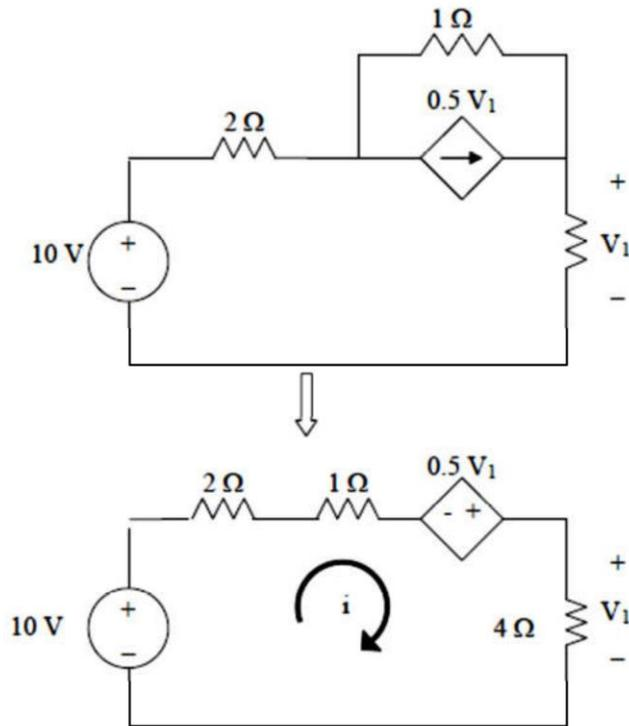

$$-10 + 7i - 0.5V_1 = 0$$

But $V_1 = 4i$

$$-10 = 7i - 2i = 5i \longrightarrow i = 2, \quad V_1 = 8 \text{ V}$$

To find V_2 , we use the circuit below.

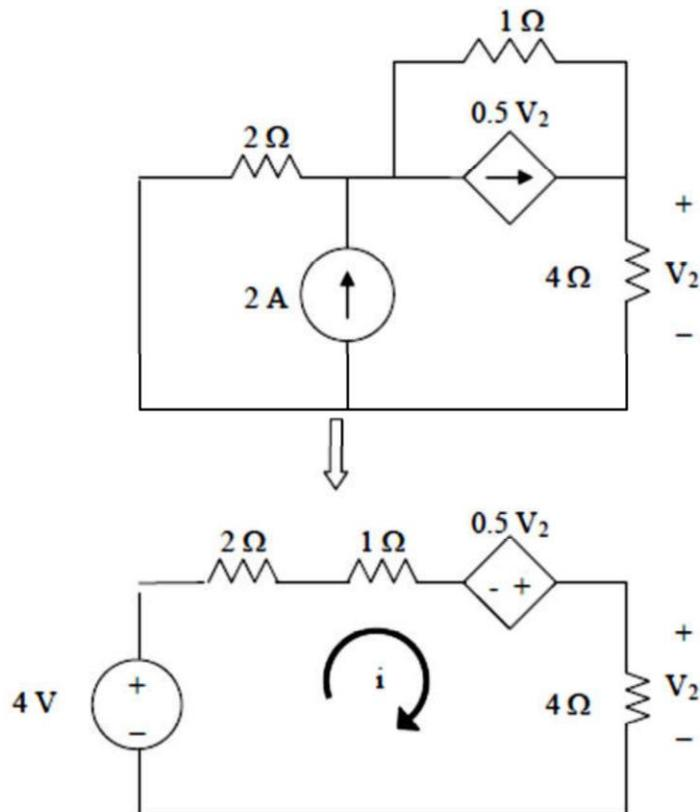

$$-4 + 7i - 0.5V_2 = 0$$

But $V_2 = 4i$

$$4 = 7i - 2i = 5i \longrightarrow i = 0.8, \quad V_2 = 4i = 3.2$$

$$V_o = V_1 + V_2 = 8 + 3.2 = 11.2 \text{ V}$$

Use superposition to solve for V_x in the circuit of

Let $v_x = v_1 + v_2$, where v_1 and v_2 are due to the 4-A and 6-A sources respectively.

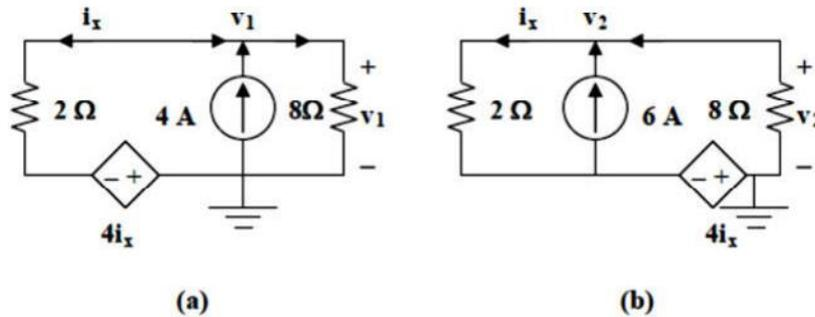

To find v_1 , consider the circuit in Fig. (a).

$$v_1/8 - 4 + (v_1 - (-4i_x))/2 = 0 \text{ or } (0.125 + 0.5)v_1 = 4 - 2i_x \text{ or } v_1 = 6.4 - 3.2i_x$$

But, $i_x = (v_1 - (-4i_x))/2$ or $i_x = -0.5v_1$. Thus,

$$v_1 = 6.4 + 3.2(0.5v_1), \text{ which leads to } v_1 = -6.4/0.6 = -10.667$$

To find v_2 , consider the circuit shown in Fig. (b).

$$v_2/8 - 6 + (v_2 - (-4i_x))/2 = 0 \text{ or } v_2 + 3.2i_x = 9.6$$

But $i_x = -0.5v_2$. Therefore,

$$v_2 + 3.2(-0.5v_2) = 9.6 \text{ which leads to } v_2 = -16$$

Hence, $v_x = -10.667 - 16 = -26.67V$.

Checking,

$$i_x = -0.5v_x = 13.333A$$

Now all we need to do now is sum the currents flowing out of the top node.

$$13.333 - 6 - 4 + (-26.67)/8 = 3.333 - 3.333 = 0$$

4.4 SOURCE TRANSFORMATION

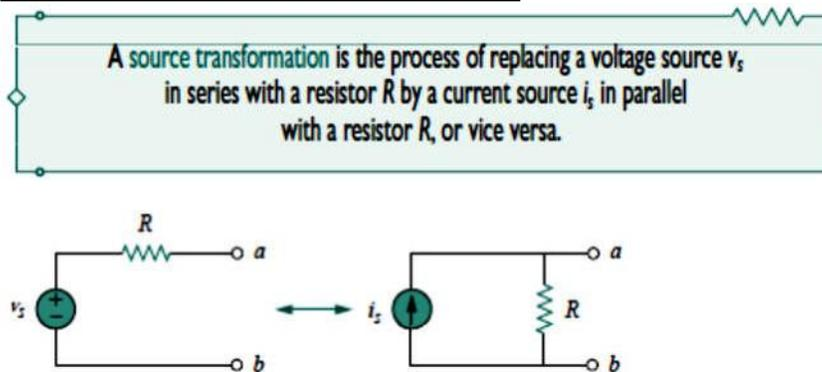

Figure 4.15 Transformation of independent sources.

The two circuits in Fig. 4.15 are equivalent—provided they have the same voltage-current relation at terminals a - b . It is easy to show that they are indeed equivalent. If the sources are turned off, the equivalent resistance at terminals a - b in both circuits is R . Also, when terminals a - b are shortcircuited the short-circuit current flowing from a to b is $i_{sc} = v_s/R$ in the circuit on the left-hand side and $i_{sc} = i_s$ for the circuit on the righthand side. Thus, $v_s/R = i_s$ in order for the two circuits to be equivalent. Hence, source transformation requires that

$$v_s = i_s R \quad \text{or} \quad i_s = \frac{v_s}{R} \quad (4.5)$$

we should keep the following points in mind when dealing with source transformation

1. Note from Fig. 4.15 (or Fig. 4.16) that the arrow of the current source is directed toward the positive terminal of the voltage source.
2. Note from Eq. (4.5) that source transformation is not possible when $R = 0$, which is the case with an ideal voltage source. However, for a practical, nonideal voltage source, $R \neq 0$. Similarly, an ideal current source with $R = \infty$ cannot be replaced by a finite voltage source. More will be said on ideal and nonideal sources

Example

Use source transformation to find in the circuit of Fig. 4.17.

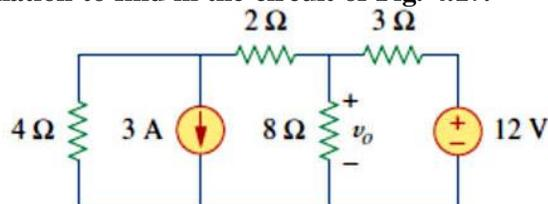

Solution:

We first transform the current and voltage sources to obtain the circuit in Fig. . (a). Combining the 4Ω and 2Ω resistors in series and transforming the 12-V voltage source gives us Fig. . (b). We now combine the 3Ω and 6Ω resistors in parallel to get 2Ω . We also combine the 2-A and 4-A current sources to get a 2-A source by repeatedly applying source transformations, we obtain the circuit in Fig.. (c).

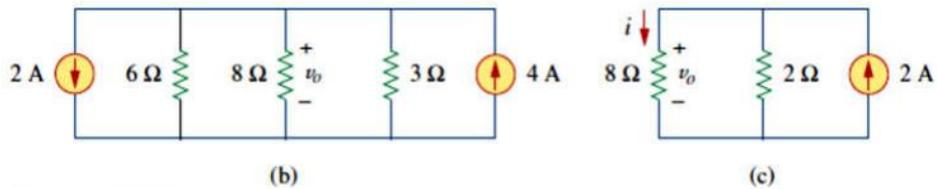
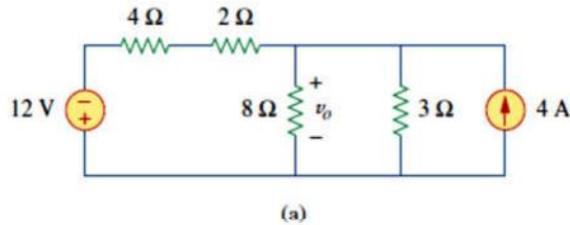

We use current division in Fig. (c) to get

$$i = \frac{2}{2 + 8}(2) = 0.4 \text{ A}$$

and

$$v_o = 8i = 8(0.4) = 3.2 \text{ V}$$

Alternatively, since the $8\text{-}\Omega$ and $2\text{-}\Omega$ resistors in Fig.. (c) are in parallel, they have the same voltage v_o across them. Hence,

$$v_o = (8 \parallel 2)(2 \text{ A}) = \frac{8 \times 2}{10}(2) = 3.2 \text{ V}$$

Practice Problem

Find i_o in the circuit of Fig. 4.19 using source transformation

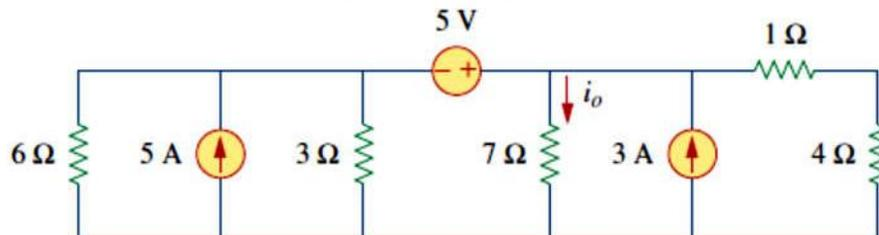

Example

Find v_x in circuit using source transformation

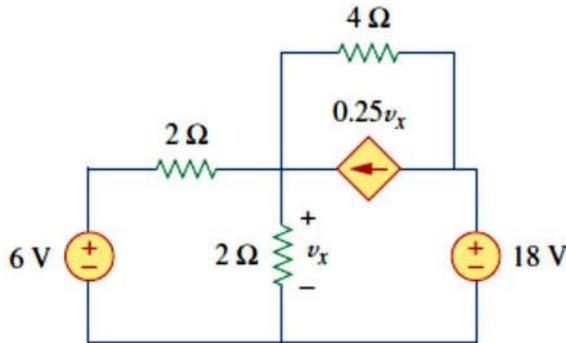

Solution:

The circuit in Fig. . involves a voltage-controlled dependent current source. We transform this dependent current source as well as the 6-V independent voltage source as shown in Fig. . (a). The 18-V voltage source is not transformed because it is not connected in series with any resistor. The two 2-Ω resistors in parallel combine to give a 1Ω resistor, which is in parallel with the 3-A current source. The current source is transformed to a voltage source as shown in Fig.(b). Notice that the terminals for v_x are intact. Applying KVL around the loop in Fig (b) gives

$$-3 + 5i + v_x + 18 = 0 \quad (4.7.1)$$

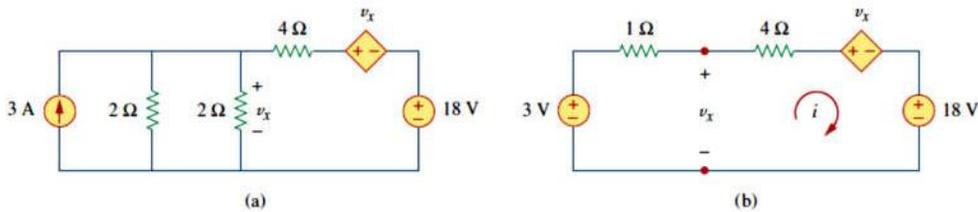

Applying KVL to the loop containing only the 3-V voltage source, the 1-Ω resistor, and v_x yields

$$-3 + 1i + v_x = 0 \Rightarrow v_x = 3 - i \quad (4.7.2)$$

Substituting this into Eq. (4.7.1), we obtain

$$15 + 5i + 3 - i = 0 \Rightarrow i = -4.5 \text{ A}$$

Alternatively, we may apply KVL to the loop containing v_x , the 4-Ω resistor, the voltage-controlled dependent voltage source, and the 18-V voltage source in Fig. (b). We obtain

$$-v_x + 4i + v_x + 18 = 0 \quad \Rightarrow \quad i = -4.5 \text{ A}$$

Thus, $v_x = 3 - i = 7.5 \text{ V}$.

Practice Problem

Use source transformation to find i_x in the circuit shown in Fig.

Answer: 7.059 mA.

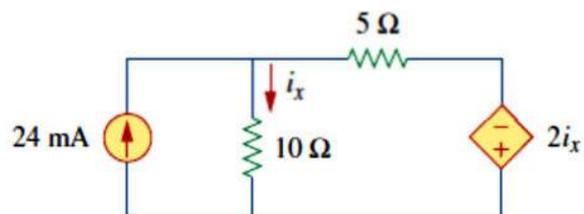

4.5 THEVENIN'S THEOREM

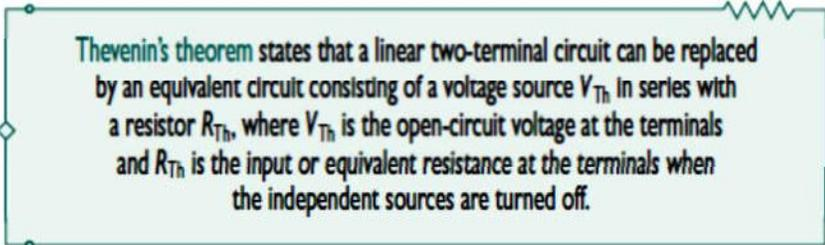

Thevenin's theorem states that a linear two-terminal circuit can be replaced by an equivalent circuit consisting of a voltage source V_{Th} in series with a resistor R_{Th} , where V_{Th} is the open-circuit voltage at the terminals and R_{Th} is the input or equivalent resistance at the terminals when the independent sources are turned off.

The following steps provide a technique which converts any circuit into its Thévenin equivalent:

1. Remove the load from the circuit.
2. Label the resulting two terminals. We will label them as a and b , although any notation may be used.
3. Set all sources in the circuit to zero. Voltage sources are set to zero by replacing them with short circuits (zero volts). Current sources are set to zero by replacing them with open circuits (zero amps).
4. Determine the Thévenin equivalent resistance, R_{Th} , by calculating the resistance “seen” between terminals a and b . It may be necessary to redraw the circuit to simplify this step.
5. Replace the sources removed in Step 3, and determine the open-circuit voltage between the terminals. If the circuit has more than one source, it may be necessary to use the superposition theorem. In that case, it will be necessary to determine the open-circuit voltage due to each source separately and then determine the combined effect. The resulting open-circuit voltage will be the value of the Thévenin voltage, E_{Th} .
6. Draw the Thévenin equivalent circuit using the resistance determined in Step 4 and the voltage calculated in Step 5. As part of the resulting circuit, include that portion of the network removed in Step 1

Example

Find the Thevenin equivalent circuit of the circuit shown in Fig. 4.27, to the left of the terminals a-b. Then find the current through $R_L = 6 \Omega, 16 \Omega, \text{ And } 36 \Omega$

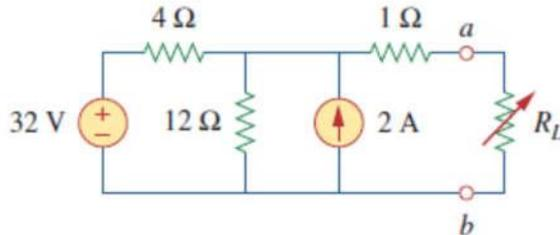

Solution:

We find R_{Th} by turning off the 32-V voltage source (replacing it with a short circuit) and the 2-A current source (replacing it with an open circuit). The circuit becomes what is shown in Fig. (a).

Thus,

$$R_{Th} = 4 \parallel 12 + 1 = \frac{4 \times 12}{16} + 1 = 4 \Omega$$

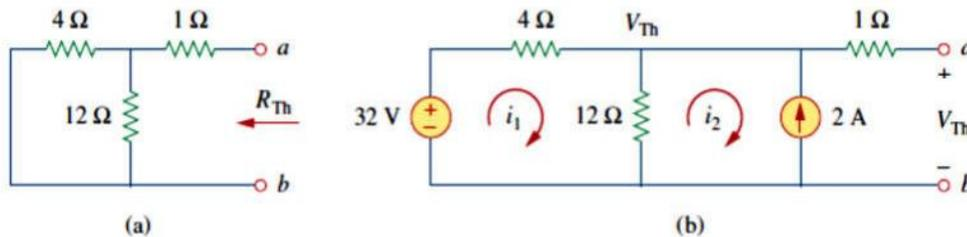

. (a) finding R_{Th} , (b) finding V_{Th} .

To find V_{Th} consider the circuit in Fig. (b). Applying mesh analysis to the two loops:

$$-32 + 4i_1 + 12(i_1 - i_2) = 0, \quad i_2 = -2 \text{ A}$$

Solving for i_1 , we get $i_1 = 0.5 \text{ A}$. Thus,

$$V_{Th} = 12(i_1 - i_2) = 12(0.5 + 2.0) = 30 \text{ V}$$

Alternatively, it is even easier to use nodal analysis. We ignore the 1-Ω resistor since no current flows through it. At the top node, KCL gives

$$\frac{32 - V_{Th}}{4} + 2 = \frac{V_{Th}}{12}$$

or

$$96 - 3V_{Th} + 24 = V_{Th} \Rightarrow V_{Th} = 30 \text{ V}$$

as obtained before. We could also use source transformation to find V_{Th} . The Thevenin equivalent circuit is shown in Fig.

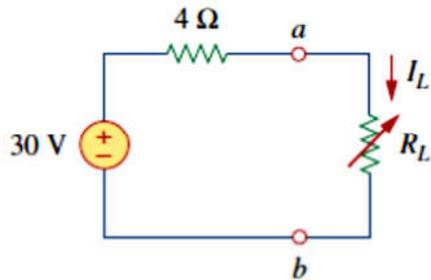

The current through R_L is

$$I_L = \frac{V_{Th}}{R_{Th} + R_L} = \frac{30}{4 + R_L}$$

When $R_L = 6$,

$$I_L = \frac{30}{10} = 3 \text{ A}$$

When $R_L = 16$,

$$I_L = \frac{30}{20} = 1.5 \text{ A}$$

When $R_L = 36$,

$$I_L = \frac{30}{40} = 0.75 \text{ A}$$

Practice Problem

Using Thevenin's theorem, find the equivalent circuit to the left of the terminals in the circuit of Fig. Then find I .

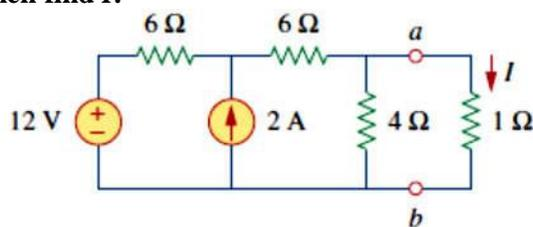

Answer: $V_{Th} = 6 \text{ V}$, $R_{Th} = 3 \Omega$, $I = 1.5 \text{ A}$.

Example

Find the Thevenin equivalent of the circuit in Fig. at terminals a - b .

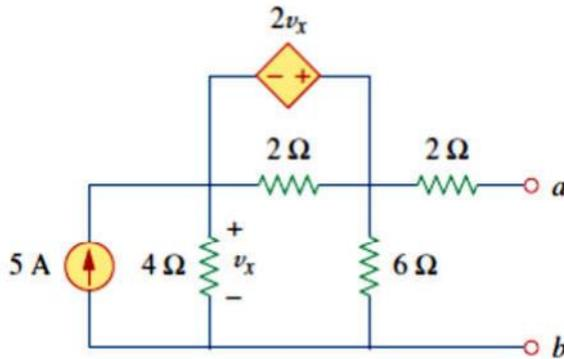

Solution:

This circuit contains a dependent source, unlike the circuit in the previous example. To find R_{Th} we set the independent source equal to zero but leave the dependent source alone. Because of the presence of the dependent source, however, we excite the network with a voltage source v_o connected to the terminals as indicated in Fig. (a). We may set $v_o = 1\text{ V}$ to ease calculation, since the circuit is linear. Our goal is to find the current i_o through the terminals, and then obtain $R_{Th} = 1/i_o$. (Alternatively, we may insert a 1-A current source, find the corresponding voltage v_o , and obtain $R_{Th} = v_o/1$.)

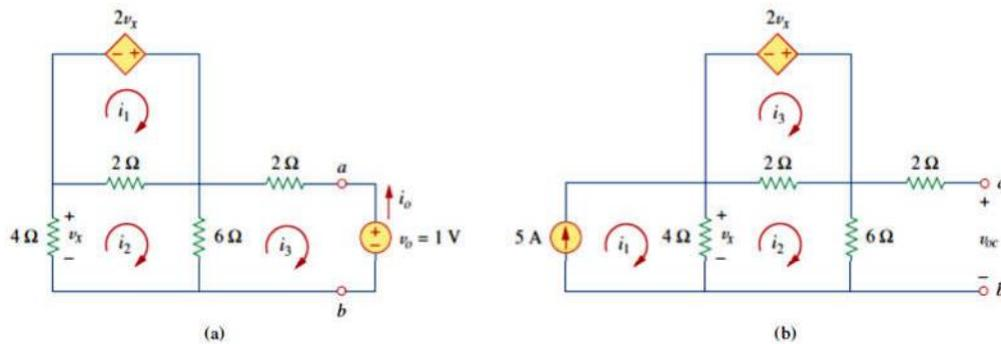

Applying mesh analysis to loop 1 in the circuit of Fig. (a) results in

$$-2v_x + 2(i_1 - i_2) = 0 \quad \text{or} \quad v_x = i_1 - i_2$$

But $-4i_2 = v_x = i_1 - i_2$; hence,

$$i_1 = -3i_2 \quad (4.9.1)$$

For loops 2 and 3, applying KVL produces

$$4i_2 + 2(i_2 - i_1) + 6(i_2 - i_3) = 0 \quad (4.9.2)$$

$$6(i_3 - i_2) + 2i_3 + 1 = 0 \quad (4.9.3)$$

Solving these equations gives

$$i_3 = -\frac{1}{6} \text{ A}$$

But $i_o = -i_3 = 1/6 \text{ A}$. Hence,

$$R_{\text{Th}} = \frac{1 \text{ V}}{i_o} = 6 \Omega$$

To get V_{Th} , we find v_{oc} in the circuit of Fig (b). Applying mesh analysis, we get

$$i_1 = 5 \quad (4.9.4)$$

$$-2v_x + 2(i_3 - i_2) = 0 \quad \Rightarrow \quad v_x = i_3 - i_2 \quad (4.9.5)$$

$$4(i_2 - i_1) + 2(i_2 - i_3) + 6i_2 = 0$$

or

$$12i_2 - 4i_1 - 2i_3 = 0 \quad (4.9.6)$$

But $4(i_1 - i_2) = v_x$. Solving these equations leads to $i_2 = 10/3$. Hence,

$$V_{\text{Th}} = v_{oc} = 6i_2 = 20 \text{ V}$$

The Thevenin equivalent is as shown in Fig.

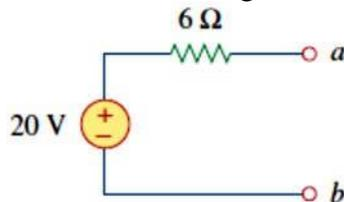

The Thevenin equivalent of the circuit:

Practice Problem

Find the Thevenin equivalent circuit of the circuit to the left of the terminals

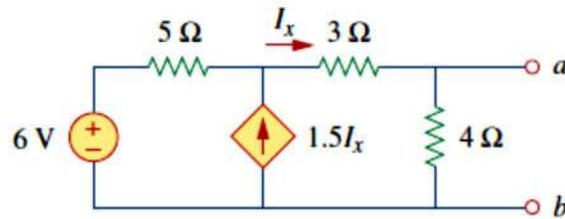

Answer: $V_{Th} = 5.333 \text{ V}$, $R_{Th} = 444.4 \text{ m}\Omega$.

Example

Determine the Thevenin equivalent of the circuit in Fig.4-35 (a) at terminals $a-b$.

Solution:

1. **Define.** The problem is clearly defined; we are to determine the Thevenin equivalent of the circuit shown in Fig. 4.35(a).
2. **Present.** The circuit contains a $2\text{-}\Omega$ resistor in parallel with a $4\text{-}\Omega$ resistor. These are, in turn, in parallel with a dependent current source. It is important to note that there are no independent sources.
3. **Alternative.** The first thing to consider is that, since we have no independent sources in this circuit, we must excite the circuit externally. In addition, when you have no independent sources you will not have a value for V_{Th} ; you will only have to find R_{Th} .

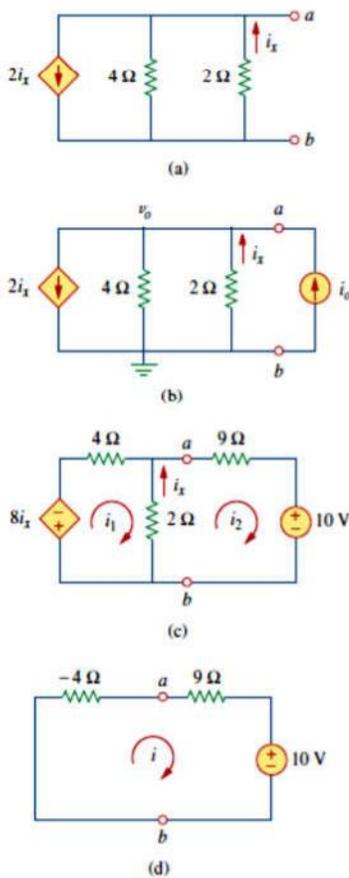

Figure 4.35
 For Example 4.10.

The simplest approach is to excite the circuit with either a 1-V voltage source or a 1-A current source. Since we will end up with an equivalent resistance (either positive or negative), I prefer to use the current source and nodal analysis which will yield a voltage at the output terminals equal to the resistance (with 1 A flowing in, v_o is equal to 1 times the equivalent resistance).

As an alternative, the circuit could also be excited by a 1-V voltage source and mesh analysis could be used to find the equivalent resistance.

4. **Attempt.** We start by writing the nodal equation at a in Fig. 4.35(b) assuming $i_o = 1\text{ A}$.

$$2i_x + (v_o - 0)/4 + (v_o - 0)/2 + (-1) = 0 \quad (4.10.1)$$

Since we have two unknowns and only one equation, we will need a constraint equation.

$$i_x = (0 - v_o)/2 = -v_o/2 \quad (4.10.2)$$

Substituting Eq. (4.10.2) into Eq. (4.10.1) yields

$$\begin{aligned} 2(-v_o/2) + (v_o - 0)/4 + (v_o - 0)/2 + (-1) &= 0 \\ = (-1 + \frac{1}{4} + \frac{1}{2})v_o - 1 \quad \text{or} \quad v_o &= -4\text{ V} \end{aligned}$$

Since $v_o = 1 \times R_{Th}$, then $R_{Th} = v_o/1 = -4\ \Omega$.

The negative value of the resistance tells us that, according to the passive sign convention, the circuit in Fig. 4.35(a) is supplying power. Of course, the resistors in Fig. 4.35(a) cannot supply power (they absorb power); it is the dependent source that supplies the power. This is an example of how a dependent source and resistors could be used to simulate negative resistance.

5. **Evaluate.** First of all, we note that the answer has a negative value. We know this is not possible in a passive circuit, but in this circuit we do have an active device (the dependent current source). Thus, the equivalent circuit is essentially an active circuit that can supply power.

Now we must evaluate the solution. The best way to do this is to perform a check, using a different approach, and see if we obtain the same solution. Let us try connecting a $9\text{-}\Omega$ resistor in series with a 10-V voltage source across the output terminals of the original circuit and then the Thevenin equivalent. To make the circuit easier to solve, we can take and change the parallel current source and $4\text{-}\Omega$ resistor to a series voltage source and $4\text{-}\Omega$ resistor by using source transformation. This, with the new load, gives us the circuit shown in Fig. 4.35(c).

We can now write two mesh equations.

$$8i_x + 4i_1 + 2(i_1 - i_2) = 0$$

$$2(i_2 - i_1) + 9i_2 + 10 = 0$$

Note, we only have two equations but have 3 unknowns, so we need a constraint equation. We can use

$$i_x = i_2 - i_1$$

This leads to a new equation for loop 1. Simplifying leads to

$$(4 + 2 - 8)i_1 + (-2 + 8)i_2 = 0$$

or

$$-2i_1 + 6i_2 = 0 \quad \text{or} \quad i_1 = 3i_2$$

$$-2i_1 + 11i_2 = -10$$

Substituting the first equation into the second gives

$$-6i_2 + 11i_2 = -10 \quad \text{or} \quad i_2 = -10/5 = -2 \text{ A}$$

Using the Thevenin equivalent is quite easy since we have only one loop, as shown in Fig. 4.35(d).

$$-4i + 9i + 10 = 0 \quad \text{or} \quad i = -10/5 = -2 \text{ A}$$

6. **Satisfactory?** Clearly we have found the value of the equivalent circuit as required by the problem statement. Checking does validate that solution (we compared the answer we obtained by using the equivalent circuit with one obtained by using the load with the original circuit). We can present all this as a solution to the problem.

Practice Problem

Obtain the Thevenin equivalent of the circuit in Fig

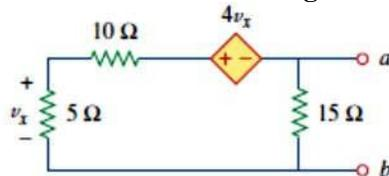

Answer: $V_{Th} = 0 \text{ V}$, $R_{Th} = -7.5 \Omega$.

4.6 NORTON'S THEOREM

Norton's theorem states that a linear two-terminal circuit can be replaced by an equivalent circuit consisting of a current source I_N in parallel with a resistor R_N , where I_N is the short-circuit current through the terminals and R_N is the input or equivalent resistance at the terminals when the independent sources are turned off.

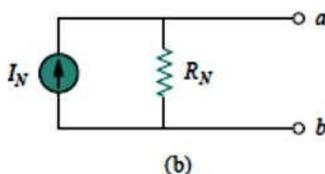

$$R_N = R_{Th}$$

$$I_N = i_{sc}$$

The following steps provide a technique which allows the conversion of any circuit into its Norton equivalent:

1. Remove the load from the circuit.
2. Label the resulting two terminals. We will label them as a and b , although any notation may be used.
3. Set all sources to zero. As before, voltage sources are set to zero by replacing them with short circuits and current sources are set to zero by replacing them with open circuits.
4. Determine the Norton equivalent resistance, R_N , by calculating the resistance seen between terminals a and b . It may be necessary to redraw the circuit to simplify this step.
5. Replace the sources removed in Step 3, and determine the current which would occur in a short if the short were connected between terminals a and b . If the original circuit has more than one source, it may be necessary to use the superposition theorem. In this case, it will be necessary to determine the short-circuit current due to each source separately and then determine the combined effect. The resulting short-circuit current will be the value of the Norton current I_N .
6. Sketch the Norton equivalent circuit using the resistance determined in Step 4 and the current calculated in Step 5. As part of the resulting circuit, include that portion of the network removed in Step 1. The Norton equivalent circuit may also be determined directly from the Thévenin equivalent circuit by using the source conversion technique

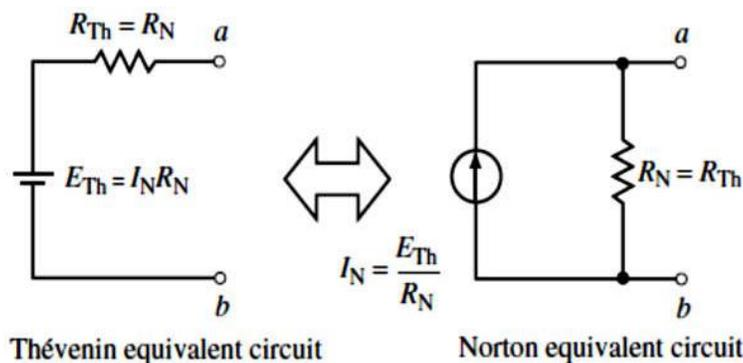
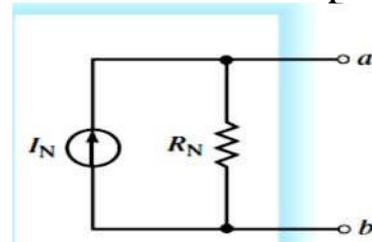

we see that the relationship between the circuits is as follows:

$$E_{Th} = I_N R_N$$

$$I_N = \frac{E_{Th}}{R_{Th}}$$

Example

Find the Norton equivalent circuit of the circuit in Fig. 4.39 at terminals a - b .

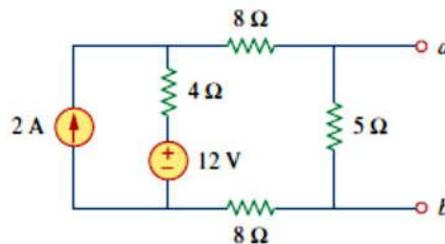

Solution:

We find R_N in the same way we find R_{Th} in the Thevenin equivalent circuit. Set the independent sources equal to zero. This leads to the circuit in Fig. 4.40(a), from which we find R_N . Thus,

$$R_N = 5 \parallel (8 + 4 + 8) = 5 \parallel 20 = \frac{20 \times 5}{25} = 4 \Omega$$

To find I_N , we short-circuit terminals a and b , as shown in Fig. (b). We ignore the 5- Ω resistor because it has been short-circuited. Applying mesh analysis, we obtain

$$i_1 = 2 \text{ A}, \quad 20i_2 - 4i_1 - 12 = 0$$

From these equations, we obtain

$$i_2 = 1 \text{ A} = i_{sc} = I_N$$

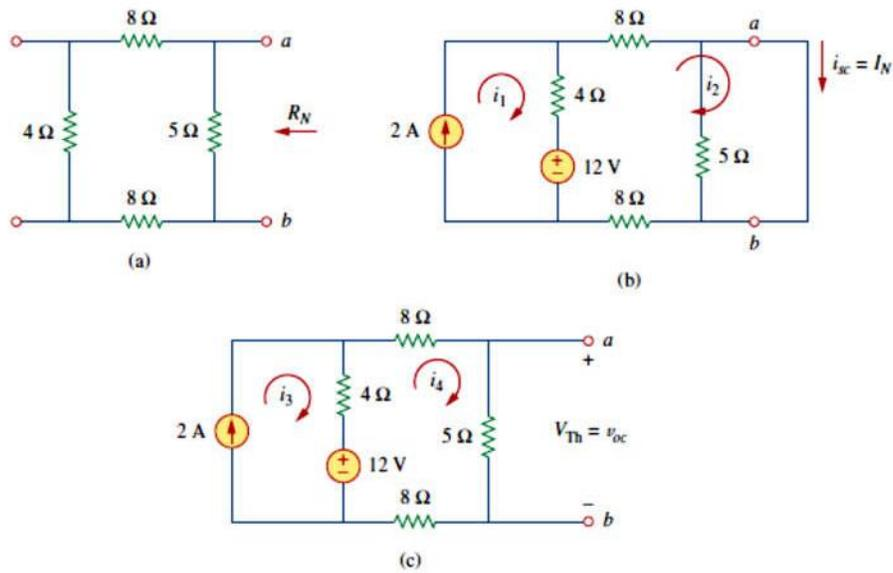

finding: (a) R_N , (b) $I_N = i_{sc}$, (c) $V_{Th} = v_{oc}$.

Alternatively, we may determine I_N from V_{Th} / R_{Th} . We obtain V_{Th} as the open-circuit voltage across terminals a and b in Fig (c). Using mesh analysis, we obtain

$$i_3 = 2 \text{ A}$$

$$25i_4 - 4i_3 - 12 = 0 \Rightarrow i_4 = 0.8 \text{ A}$$

and

$$v_{oc} = V_{Th} = 5i_4 = 4 \text{ V}$$

Hence,

$$I_N = \frac{V_{Th}}{R_{Th}} = \frac{4}{4} = 1 \text{ A}$$

$R_{Th} = v_{oc}/i_{sc} = 4/1 = 4 \Omega$. Thus, the Norton equivalent circuit is as shown in Fig..

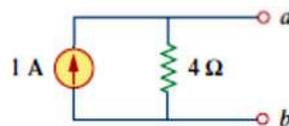

Norton equivalent:

Practice Problem

Find the Norton equivalent circuit for the circuit in Fig. 4.42, at terminals a - b .

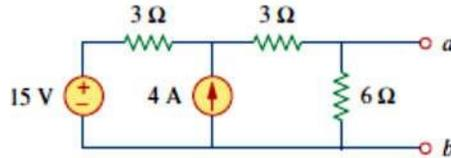

Answer: $R_N = 3 \Omega, I_N = 4.5 \text{ A}$.

Example

Using Norton's theorem, find R_N and I_N of the circuit at terminals a - b .

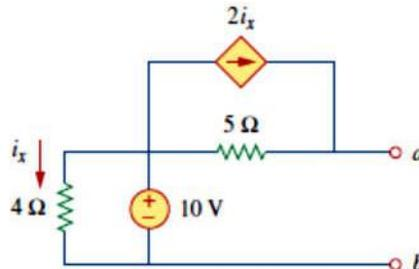

Solution:

To find R_N , we set the independent voltage source equal to zero and connect a voltage source of $v_o = 1 \text{ V}$ (or any unspecified voltage v_o) to the terminals. We obtain the circuit in Fig. (a). We ignore the $4\text{-}\Omega$ resistor because it is short-circuited. Also due to the short circuit, the $5\text{-}\Omega$ resistor, the voltage source, and the dependent current source are all in parallel. Hence, $i_x = 0$. At node a , $i_o = \frac{v_o}{5\Omega} = 0.2 \text{ A}$, and

$$R_N = \frac{v_o}{i_o} = \frac{1}{0.2} = 5 \Omega$$

To find I_N , we short-circuit terminals a and b and find the current

i_{sc} , as indicated in Fig. (b). Note from this figure that the resistor, the 10-V voltage source, the resistor, and the dependent current source are all in parallel. Hence,

$$i_x = \frac{10}{4} = 2.5 \text{ A}$$

At node a , KCL gives

$$i_{sc} = \frac{10}{5} + 2i_x = 2 + 2(2.5) = 7 \text{ A}$$

Thus,

$$I_N = 7 \text{ A}$$

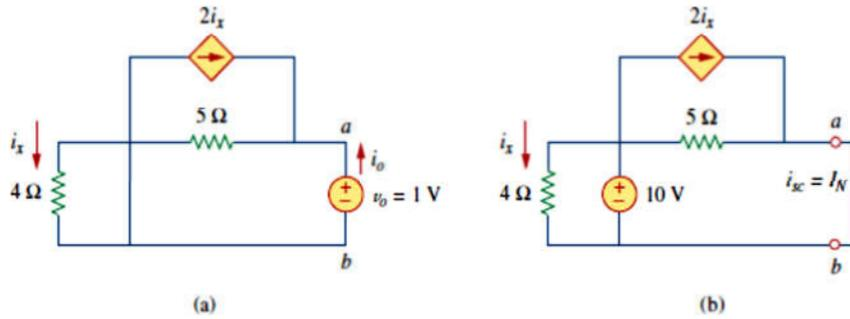

(a) finding R_N , (b) finding I_N .

Practice Problem

Find the Norton equivalent circuit of the circuit in Fig. terminals a - b .

Answer: $R_N = 1 \Omega$, $I_N = 10 \text{ A}$.

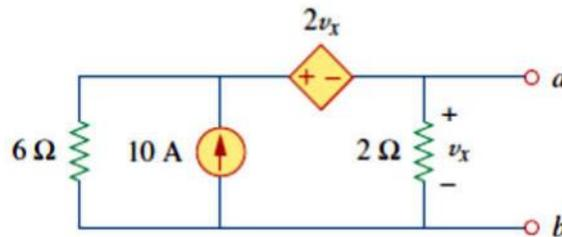

MAXIMUM POWER TRANSFER

The Thevenin equivalent is useful in finding the maximum power a linear circuit can deliver to a load. We assume that we can adjust the load resistance R_L . If the entire circuit is replaced by its Thevenin equivalent except for the load, as shown in Fig. 4.48, the power delivered to the load is

$$p = i^2 R_L = \left(\frac{V_{Th}}{R_{Th} + R_L} \right)^2 R_L \quad (4.21)$$

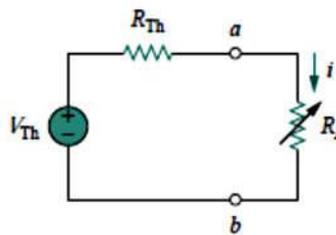

Figure 4.48 The circuit used for maximum power transfer.

maximum power transfer.

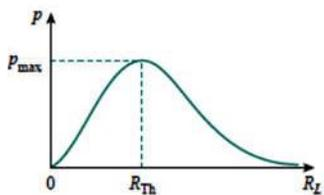

Figure 4.49 Power delivered to the load

For a given circuit, V_{Th} and R_{Th} are fixed. By varying the load resistance R_L , the power delivered to the load varies as sketched in Fig. 4.49. We notice from Fig. 4.49 that the power is small for small or large values of R_L but maximum for some value of R_L between 0 and ∞ . We now want to show that this maximum power occurs when R_L is equal to R_{Th} . This is known as the *maximum power theorem*.

Maximum power is transferred to the load when the load resistance equals the Thevenin resistance as seen from the load ($R_L = R_{Th}$).

The maximum power transferred is

$$p_{\max} = \frac{V_{Th}^2}{4R_{Th}}$$

Example

Find the value of for maximum power transfer in the circuit. Find the maximum power

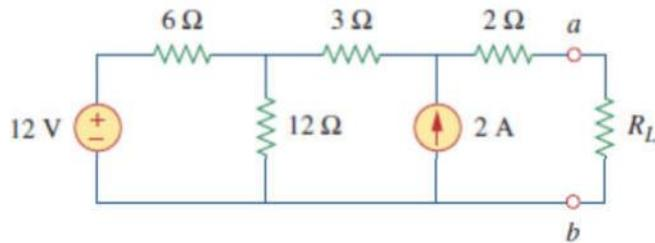

Solution:

We need to find the Thevenin resistance R_{Th} and the Thevenin voltage V_{Th} across the terminals $a-b$. To get R_{Th} , we use the circuit in Fig. 4.51(a) and obtain

$$R_{Th} = 2 + 3 + 6 \parallel 12 = 5 + \frac{6 \times 12}{18} = 9 \Omega$$

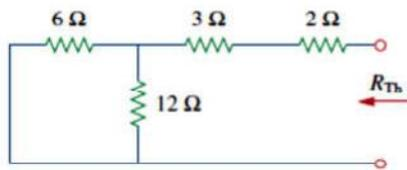

(a)

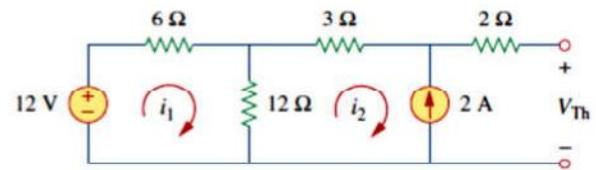

(b)

(a) finding R_{Th} , (b) finding V_{Th}

To get V_{Th} , we consider the circuit in Fig. 4.51(b). Applying mesh analysis,

$$-12 + 18i_1 - 12i_2 = 0, \quad i_2 = -2 \text{ A}$$

Solving for i_1 , we get $i_1 = -2/3$. Applying KVL around the outer loop to get V_{Th} across terminals $a-b$, we obtain

$$-12 + 6i_1 + 3i_2 + 2(0) + V_{Th} = 0 \quad \Rightarrow \quad V_{Th} = 22 \text{ V}$$

For maximum power transfer,

$$R_L = R_{Th} = 9 \Omega$$

and the maximum power is

$$p_{\max} = \frac{V_{Th}^2}{4R_L} = \frac{22^2}{4 \times 9} = 13.44 \text{ W}$$

Practice Problem

Determine the value of R_L that will draw the maximum power from the rest of the circuit in Fig. 4.52. Calculate the maximum power.

Answer: 4.22 Ω , 2.901 W.

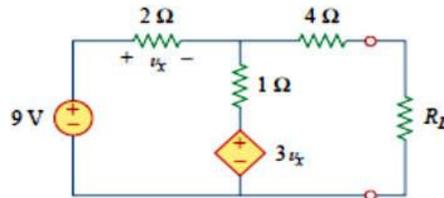

Summary

1. A linear network consists of linear elements, linear dependent sources, and linear independent sources.
2. Network theorems are used to reduce a complex circuit to a simpler one, thereby making circuit analysis much simpler.
3. The superposition principle states that for a circuit having multiple independent sources, the voltage across (or current through) an element is equal to the algebraic sum of all the individual voltages (or currents) due to each independent source acting one at a time.
4. Source transformation is a procedure for transforming a voltage source in series with a resistor to a current source in parallel with a resistor, or vice versa.
5. Thevenin's and Norton's theorems allow us to isolate a portion of a network while the remaining portion of the network is replaced by an equivalent network. The Thevenin equivalent consists of a voltage source V_{Th} in series with a resistor R_{Th} , while the Norton equivalent consists of a current source I_N in parallel with a resistor R_N . The two theorems are related by source transformation.

$$R_N = R_{Th}, \quad I_N = \frac{V_{Th}}{R_{Th}}$$

6. For a given Thevenin equivalent circuit, maximum power transfer occurs when $R_L = R_{Th}$; that is, when the load resistance is equal to the Thevenin resistance.
7. The maximum power transfer theorem states that the maximum power is delivered by a source to the load R_L when R_L is equal to R_{Th} , the Thevenin resistance at the terminals of the load.
8. *PSpice* can be used to verify the circuit theorems covered in this chapter.
9. Source modeling and resistance measurement using the Wheatstone bridge provide applications for Thevenin's theorem.